

Smart Blind Lite

User Manual

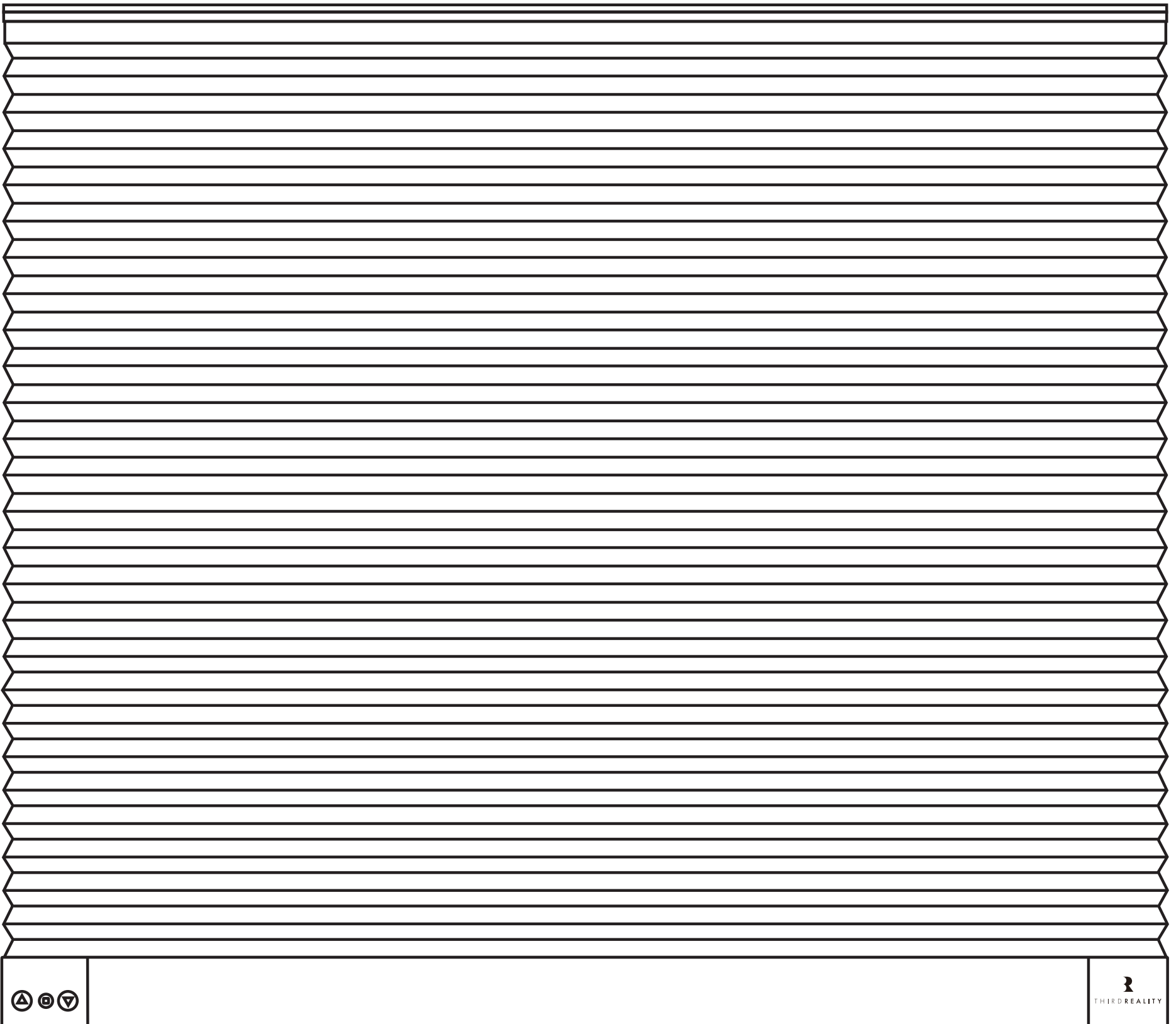

Contents

Product Instruction	1
Product Features	1
Product Details	3
Installation	4
Local Using of Smart Blind Lite	10
Pairing with Different Brands	11
Pairing with Amazon Echo	11
Pairing with Eero	13
Pairing with SmartThings	14
Pairing with Home Assistant	16
Pairing with Third Reality	17
Pairing with Hubitat	18
Troubleshooting	19
FCC Regulatory Conformance	22
RF Exposure	23
Limited Warranty	23

Product Instruction

THIRDREALITY Zigbee Smart Blind Lite, a smart honeycomb curtain with simple installation and convenient control (both online and offline). No worry about the height. The Smart Blind Lite has a thoughtful design on the bottom which can automatically detect the window sill and then stop. Smart Blind Lite is designed to run on Alkaline Batteries power and the drive units is at the bottom of blind, let the battery replacement becomes more convenient. More intelligent control like voice control, app control, create routines, setting schedules/timers and setting groups can be achieved by connecting to gateways. Such as compatible Echo devices(which have Zigbee hub built-in), SmartThings, Home Assistant, Eero 6 & Eero 6 Pro, Third Reality Hub and Hubitat.

Product Features

1 Directly work with compatible Echo devices

Smart Blind Lite is a standard Zigbee device. It can directly work with compatible Echo devices with Zigbee hub built-in (including Echo 4th Gen, Echo Plus 1st Gen and 2nd Gen, Echo Show 10 2nd Gen and 3rd Gen and Echo Studio).

2 Work with multiple platforms.

Smart Blind Lite can also connect with SmartThings, Home Assistant, Eero 6 & Eero 6 Pro, Third Reality Hub and Hubitat Elevation.

3 Unique and novel design

Smart blind Lite uses bottom drive design, which makes daily operation more convenient and easier to replace the battery. With the design of bottom sensor, it's easier and more convenient to adjust the height of the blind within 72-inch at any time.

4 No worry about power support

With more than 6 months battery life, AA batteries are cheap and easy to change. No worry about whether your window is too high to charge or without an outlet. No worry about batteries is dead, but it is hard to find replacement batteries.

5 Functions provided by Alexa App

Smart Blind Lite works with Alexa and it has multiple functions, including schedule, group and routine. Set your blind on or open according to the sunset or sunrise time, etc.

Product Details

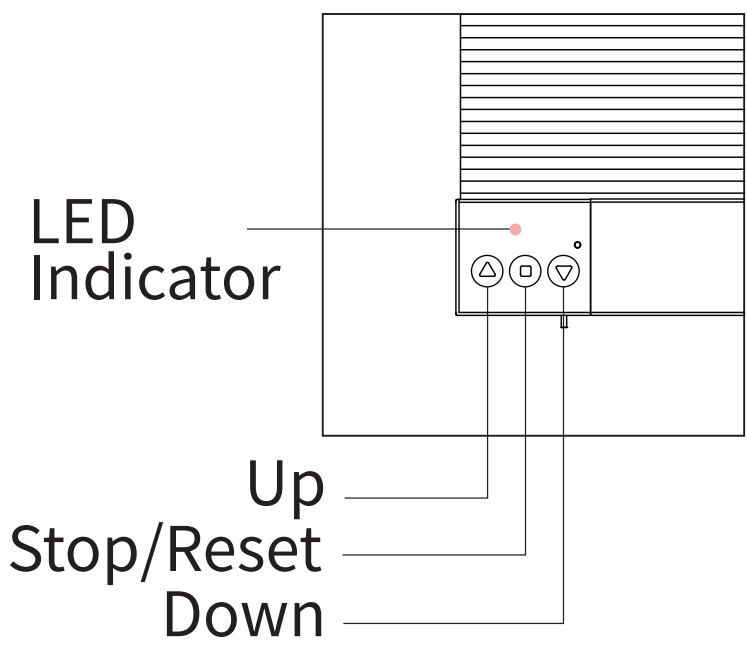
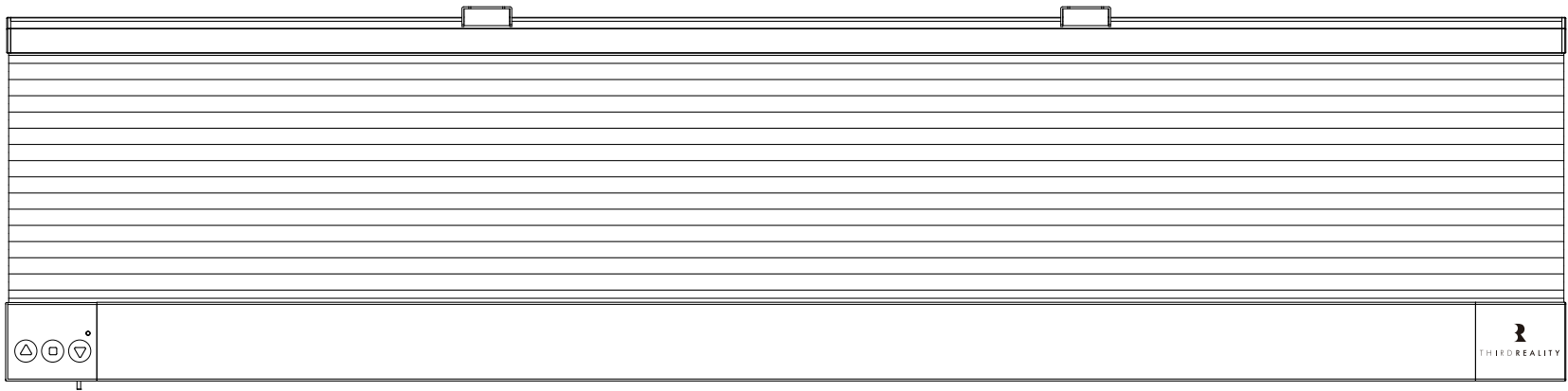

LED Status & Buttons

- Fast blinking : pairing
- Slow blinking: off-line
- Double blinking: low power
- Up: retract
- Stop/Reset: single press to stop/long press to enter pairing mode
- Down: extend

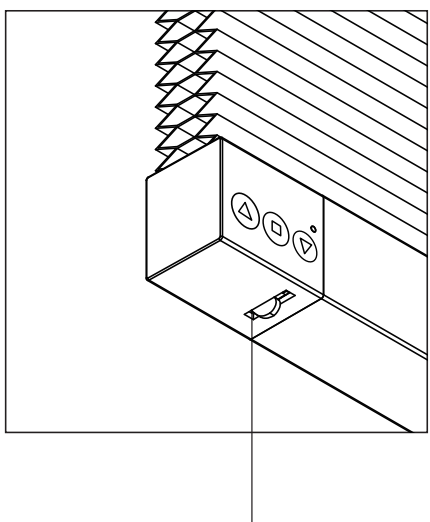

Bottom Sensor

Bottom Sensor

When the Smart Blind Lite is extending, if the Bottom Sensor hits any surface (like the window sill or your finger), it will stop at this position. The Bottom Sensor is also used to set the bottom position. (See P9)

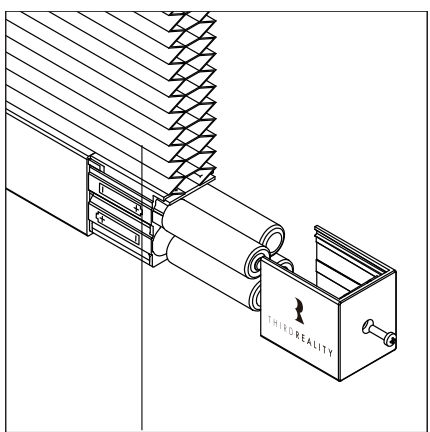

Battery Cover
(batteries sold separately)

Battery Cover

Pay attention to the positive and negative terminals of the Batteries.

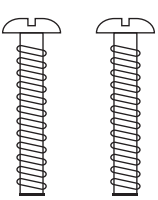

Screw × 2

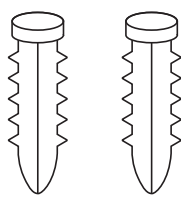

Plastic Expansion Bolt × 2

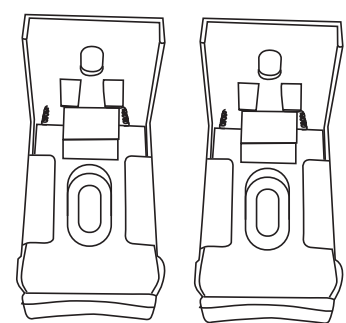

L Bracket × 2

Installation

THIRDREALITY Smart Blind Lite supports both inside and outside mount, a pair of L brackets, screws and plastic expansion bolts are provided. Please prepare a PH2 screwdriver for the mount; For masonry surface please prepare an electric drill with an M5 drill bit. Make sure the THIRDREALITY logo of the Smart Blind Lite and the button of the L brackets face in when installed.

- 1 Choose inside or outside mount as needed. Make sure your window recess meets the minimum depth requirement of 2" for inside mount. For outside mount, if you want to expose the whole window when the smart blind Lite is fully closed, make sure you have at least 4.3" of flat space above the window.
 - a. Inside Mount

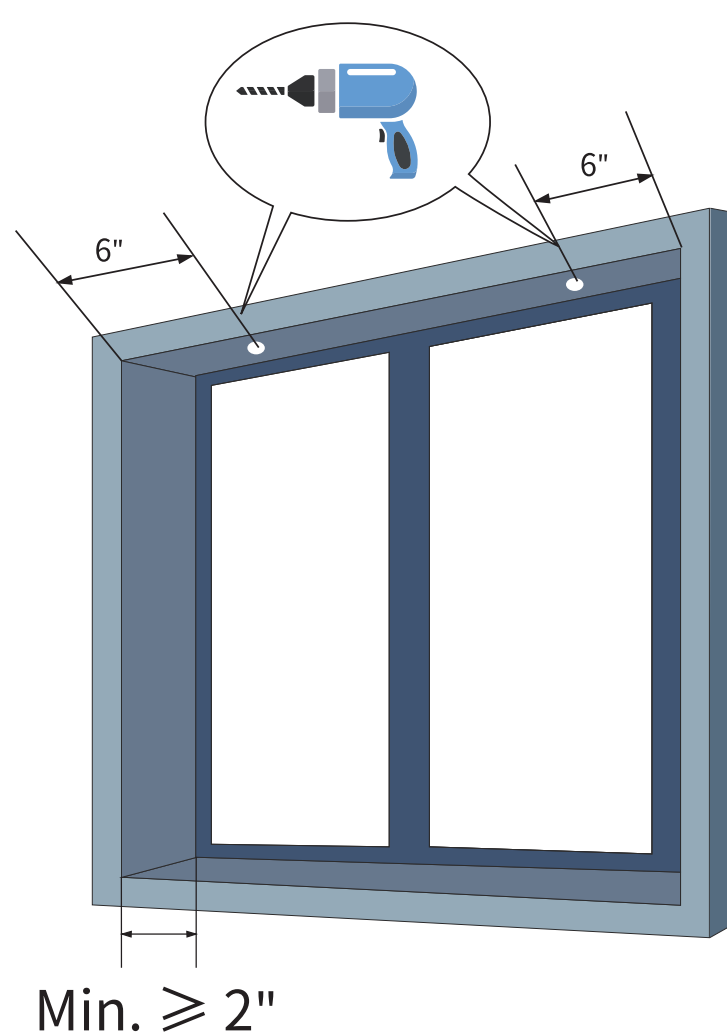

- According to the diagram, measure and mark the position;
- For wooden surface use a PH2 screwdriver and the provided screws to secure the bracket.
- For masonry surface use a M5 drill bit to drill a pilot hole for the provided plastic expansion bolt. Insert the plastic expansion bolt into the pilot hole, then use a PH2 screwdriver to secure the bracket with the provided screw.

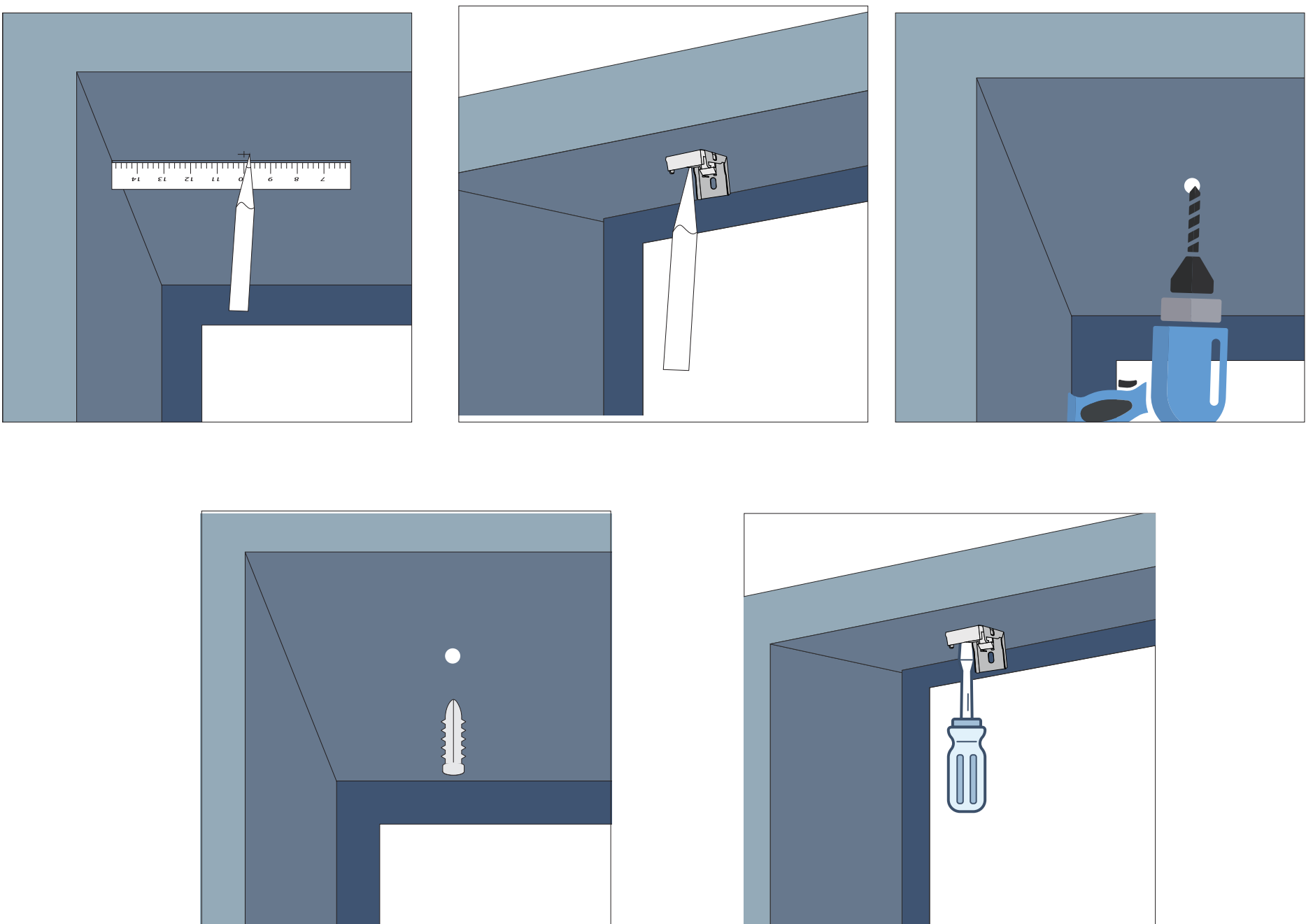

b. Outside Mount

- According to the diagram, measure and mark the corresponding position.

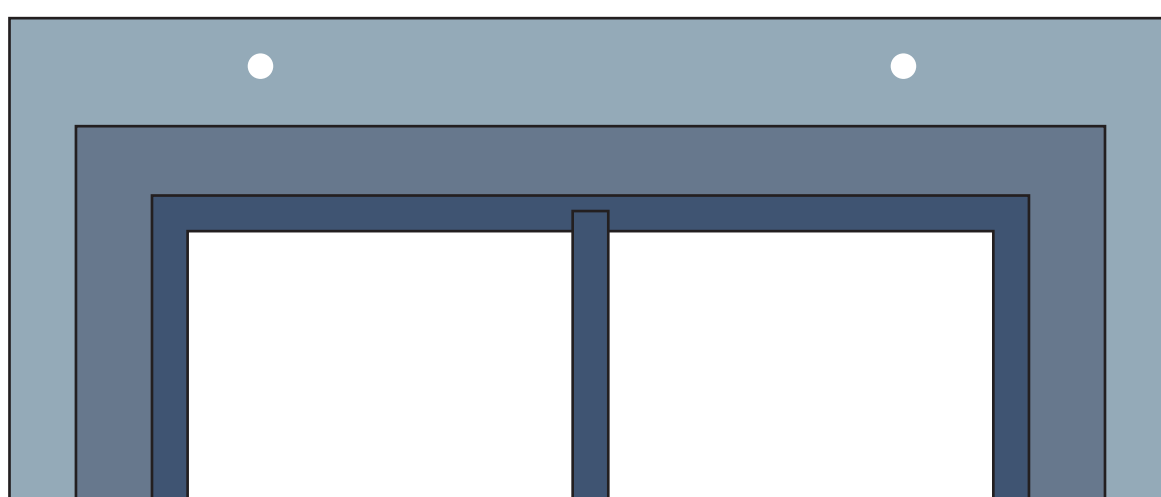
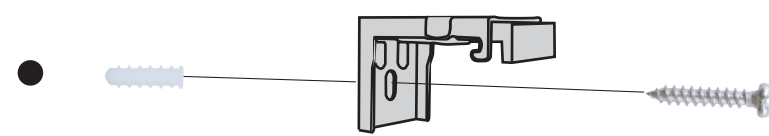
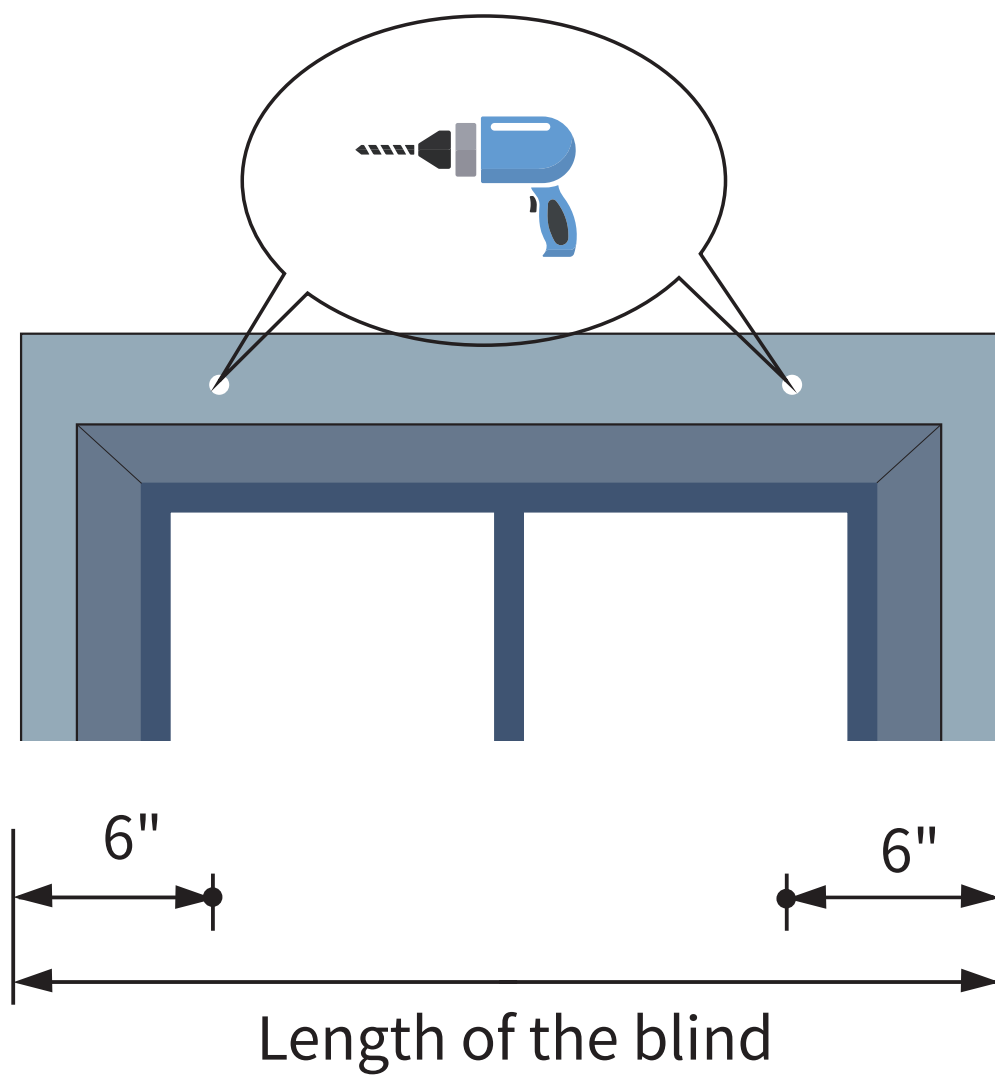

- For wooden surface use a PH2 screwdriver and the provided screw to secure the bracket.
- For masonry surface use an M5 drill bit to drill a pilot hole for the provided plastic expansion bolt. Insert the plastic expansion bolt into the pilot hole, then use a PH2 screwdriver to secure the bracket with the provided screw. Insert the plastic expansion bolt into the hole, then use a PH2 screwdriver to fasten the bracket with the provided screw.

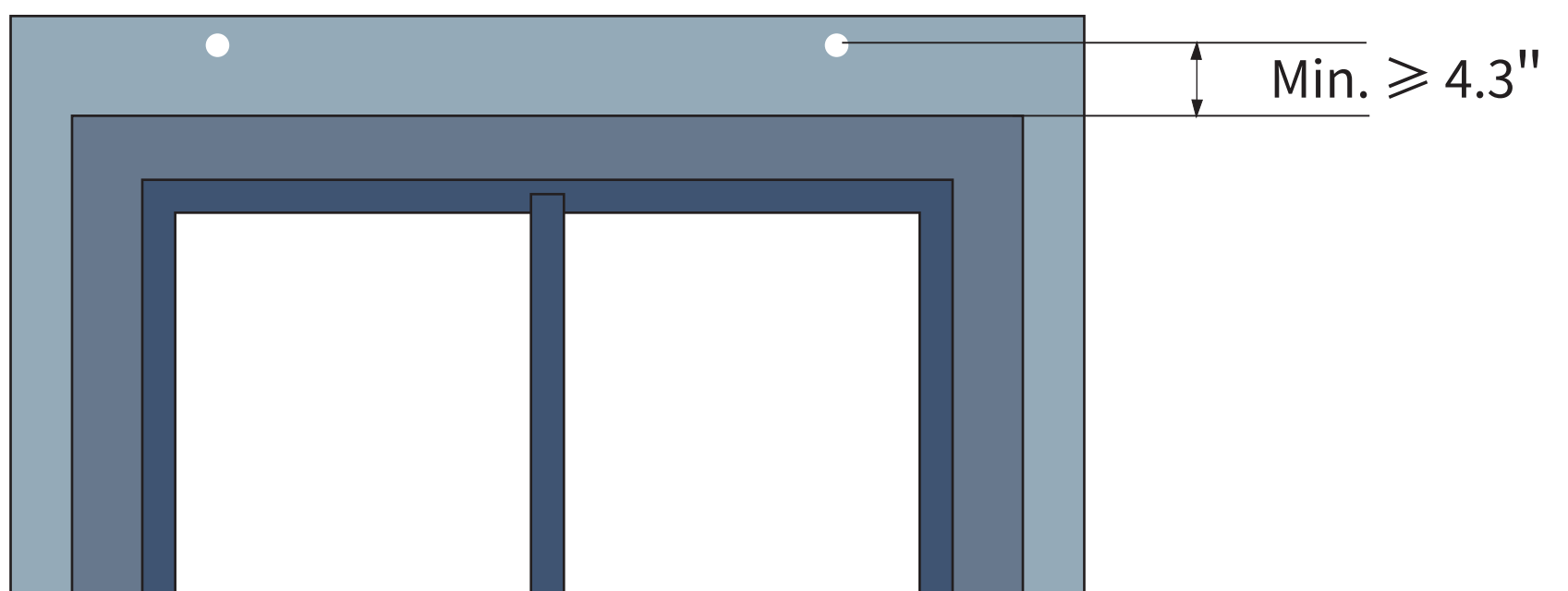
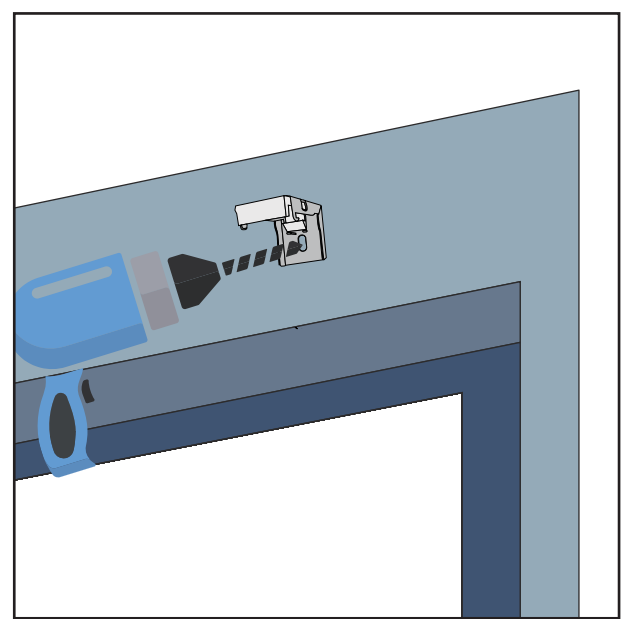
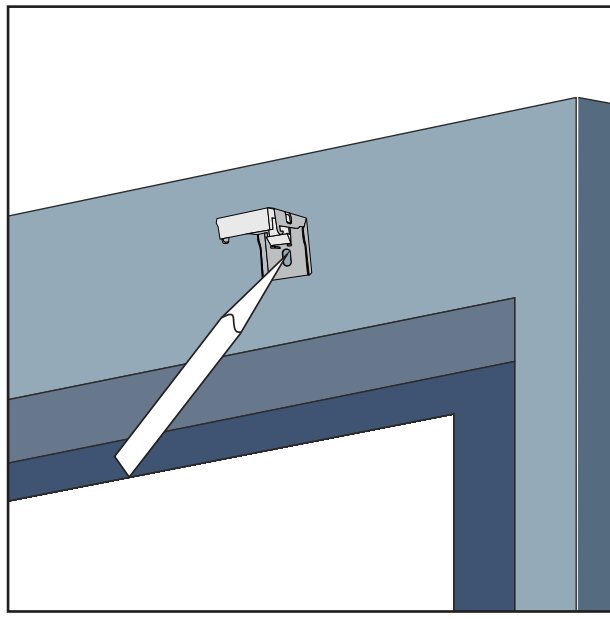
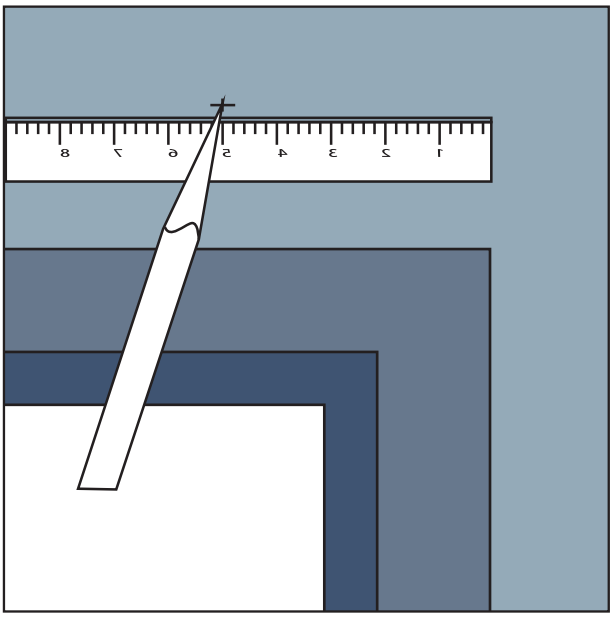

- 2** Unscrew with the PH2 screwdriver to open the battery cover, install AA batteries, close and secure the battery cover with the screw.

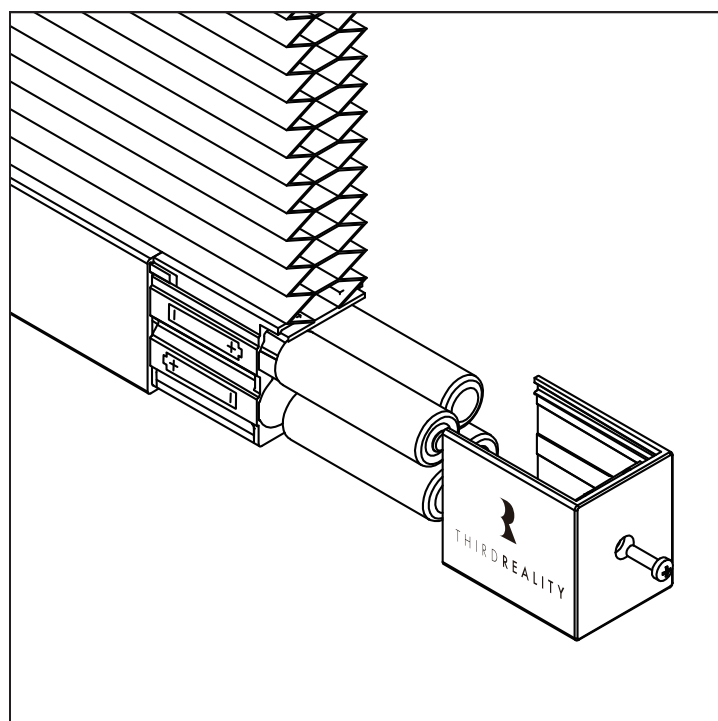

③ Outside Mount/Inside Mount

Firstly align the outside of the top rail with the brackets, then push up the Smart Blind Lite to get it into place. The bracket's button pops up and makes a clicking sound, indicating it is secured. To uninstall the Smart Blind Lite, push the button of the brackets and then pull down the Smart Blind Lite.

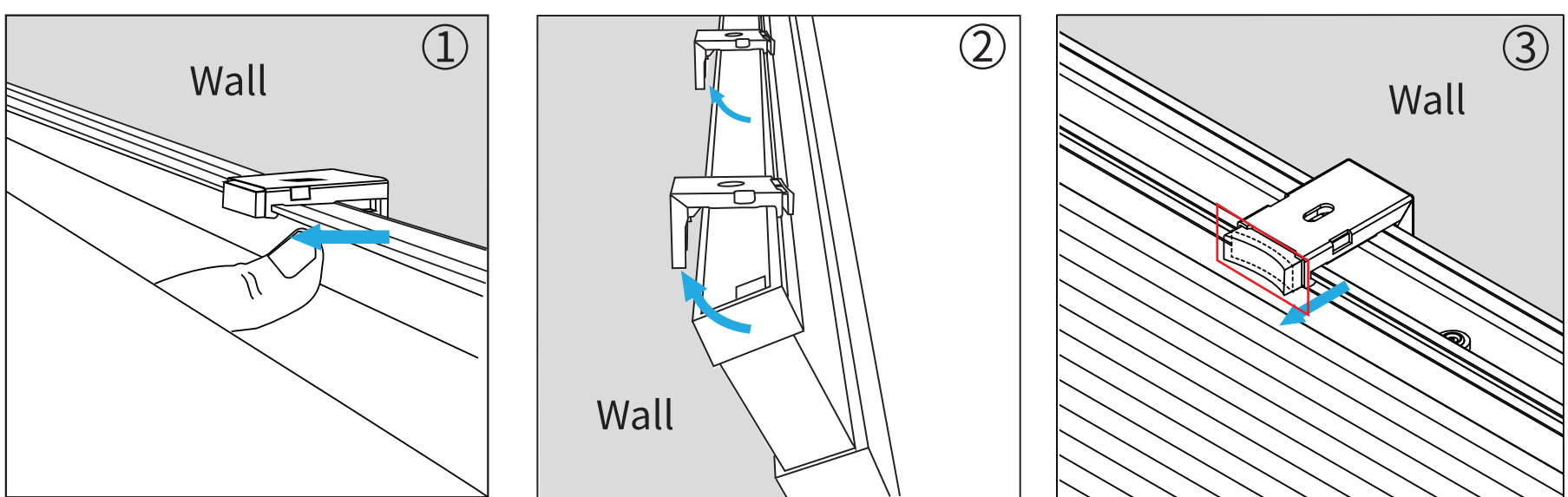

Note: Please shake the blind to ensure the blind and the Extension Bracket are in close contact.

4 Set the position where you want the bottom of your Smart Blind Lite to rest

Press the UP button and let the Smart Blind Lite retract to the highest position, now the Smart Blind Lite returns to the original zero percent. Press the DOWN button to let the Smart Blind Lite extend, stop the bottom rail at your desired position by pressing the setting/stop button. Now hold up the bottom sensor with your finger first, then press the DOWN button, after that release the DOWN button first, then release the bottom sensor, now you have set this position as the preset bottom position, the Smart Blind Lite will stop at this position automatically next time when extending.

Note: Press and hold the DOWN button on the smart blind for 5 seconds to clear the currently set bottom position.

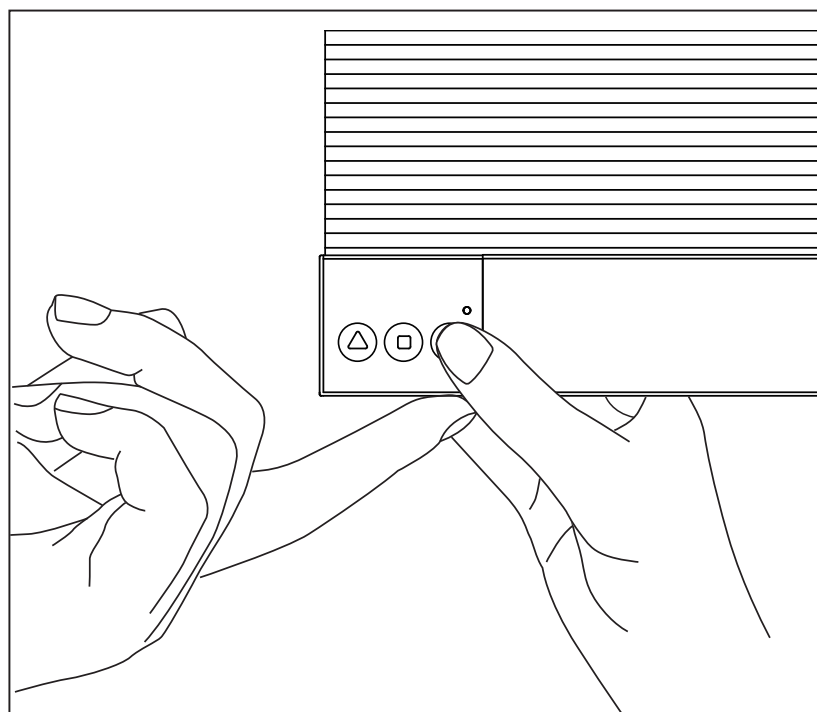

Scan this QR code with your mobile device to watch the instruction video on YouTube.



Local Using of Smart Blind Lite

Optimum height:

The height of our ThirdReality Smart Blind Lite support 72 inches at maximum.

Local Control:

You can use the remote (sold separately) or 3 control buttons on the bottom rail to control the Smart Blind Lite.

Pairing with Different Brands

Pairing with Amazon Echo

Compatible Device: Echo V4, Echo Plus V1 & V2, Echo Studio, Echo Show 10 Gen2 & Gen3

App: Amazon Alexa App



Pairing Steps:

- 1** Long press the setting button of blinds for more than 5 seconds until the LED light flashes rapidly in red, indicating that the Smart Blind is in pairing mode.
- 2** Before pairing, make sure the Echo devices have been updated to the latest version. Then directly say "**Alexa, discover my devices**". Or you can open Alexa App, go to device page, tap "+" on top right, choose "**Add Device**", then click "**other**" by sliding down, tap "**DISCOVER DEVICES**", wait for few seconds, the Smart Blind will be paired to Alexa.
- 3** After the pairing is successful, you can control the blinds by voice and App.

Using Smart Blind Lite

Optimum Height:

The height of our ThirdReality Smart Blind Lite support 72 inches at maximum.

Voice Control

- "Alexa, turn on / off first blind."
- "Alexa, set / turn on / turn off / turn up / turn down / open / close first blind to 50%."

Routines

You can create routines in your Alexa App to turn on/off the Smart Blind or set any open percentage, for example you can create a routine with a motion sensor as a trigger to open the Smart Blind when you enter the room, or you can create a routine to open / close your Smart Blind at sunrise / sunset.

Note: A voice command "Alexa, turn on first blind." cannot be interrupted by a voice command "Alexa, turn off first blind." vice versa.

A voice command "Alexa, set first blind to 80%" can be interrupted by another voice command "Alexa, set first blind to 20%."

Pairing with Eero

Compatible Devices: Eero 6 & Eero 6 Pro

App: Eero App Alexa App



Pairing Steps:

- 1** Make sure that the Eero App account is logged in and the gateway is properly connected.
- 2** Open Alexa App and register your account, then enable Eero Skill to Alexa App.
- 3** Long press the setting button of blinds for more than 5 seconds until the LED light flashes rapidly in red, indicating that the Smart Blind is in pairing mode.
- 4** Before Pairing, make sure the Echo devices have been updated to the latest version, then directly say "Alexa, discover my devices". Or you can open Alexa App, go to device page, tap "+" on top right, choose "Add Device", then click "other" by sliding down, tap "DISCOVER DEVICES", wait for few seconds, the smart blinds will be paired to Alexa.
- 5** After the pairing is successful, you can control the blinds by voice and App.

Pairing with SmartThings

Compatible Devices: SmartThings Hub 2015&2018, Aeotec
App: SmartThings App



Pairing Steps:

- 1 Long press the setting button of blinds for more than 5 seconds until the LED light flashes rapidly in red, indicating that the Smart Blind is in pairing mode.
- 2 Add SmartThings drivers for Smart Blind
 - Open this link in your PC browser. Log in your SmartThings Account.
<https://bit.ly/3BjdrXp>
 - Click "Enroll" -- "Available Drivers" -- "Install" to install the Zigbee Contact driver.

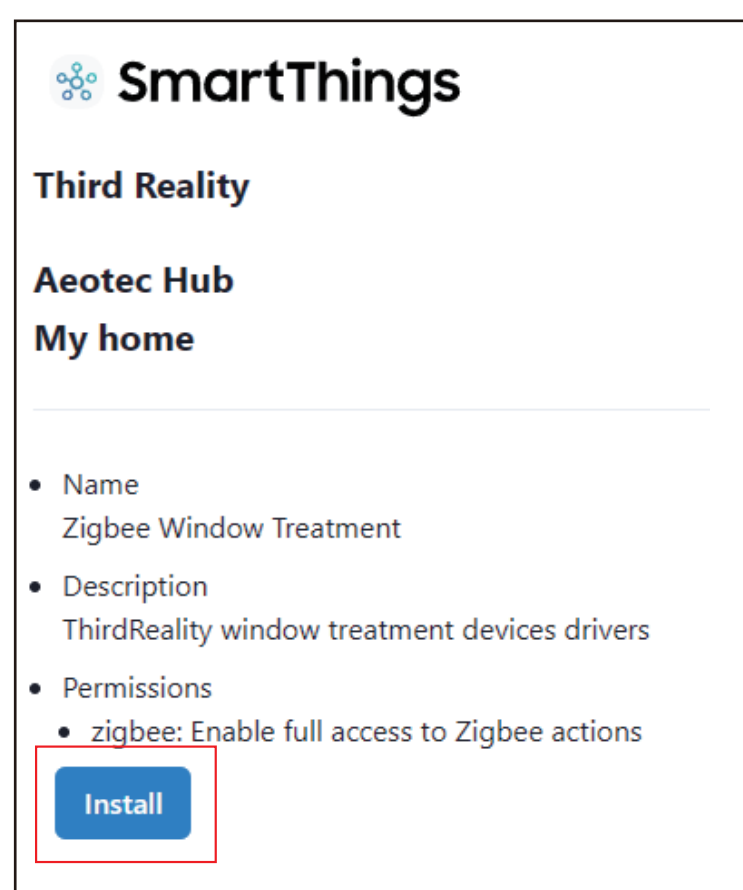
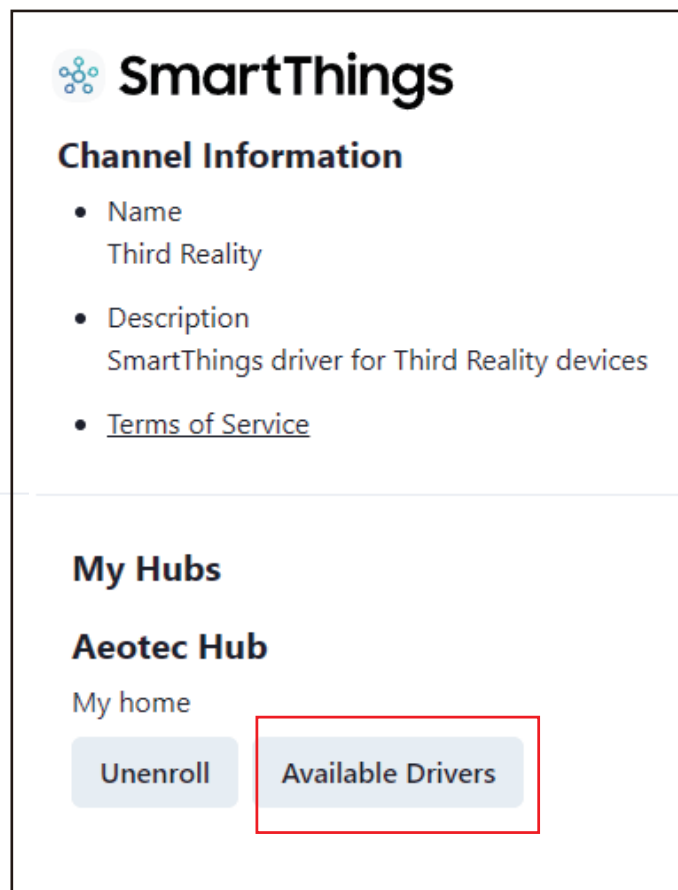
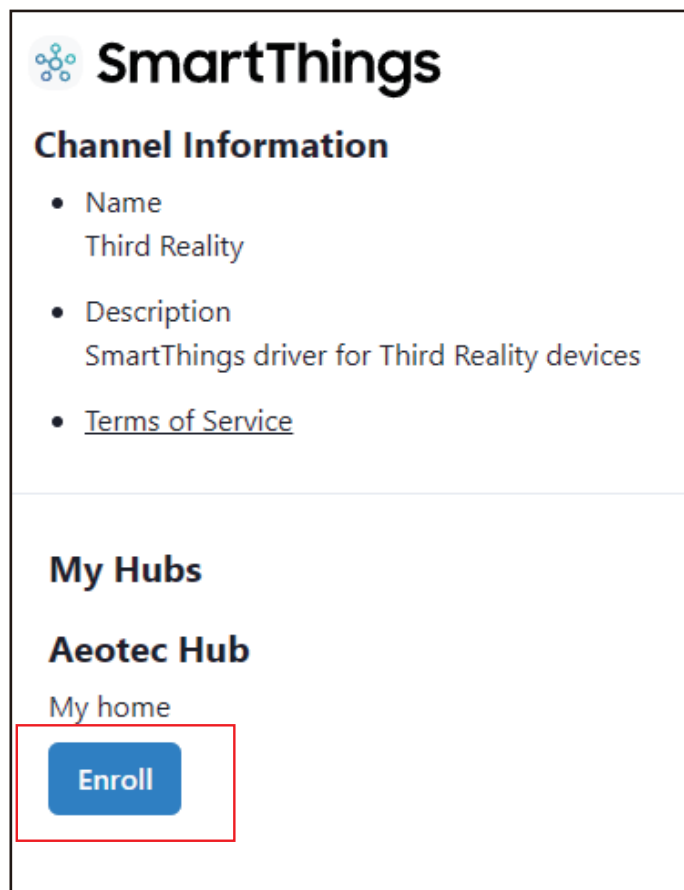

- 3 Open SmartThings App, tap "+" on top right. Then click "Add Devices", Choose "Scan nearby".
- 4 After the pairing is successful, it will be displayed as "Third Reality Smart Blind" on the page.
- 5 You can control the Smart Blind in its details page now.
- 6 You also can make your Smart Blind smarter by adding automations in the SmartThings App.

Pairing with Home Assistant

Pairing Steps:

- 1** Long press the setting button of blinds for more than 5 seconds until the LED flashes rapidly in red, indicating that the Smart Blind is in pairing mode.
- 2** Make sure Home Assistant Integrations Zigbee Home Automation Setup is ready, then click "+ Add Device" on Device Page.
- 3** After the pairing is successful, it will be shown as "Third Reality, Inc 3RSB015BZ" on the page.
- 4** Back to "Devices & Services" page, click the device list under the "HubZ Smart Home Controller" button, then you can find the Smart Blind added before. Click to enter in the control interface to operate the Smart Blind.
- 5** You can add "Automated Actions" and check device status on the "Device" page.

Pairing with Third Reality

ZigBee Hub Prepare: Third Reality Smart Hub
App: Third Reality App



Pairing Steps:

- 1 Long press the setting button of blinds for more than 5 seconds until the LED light flashes rapidly in red, indicating that the Smart Blind is in pairing mode.
- 2 Open Third Reality App, go to device page, tap "+" belongs to the Hub, choose "**Smart Blind**", then click "**Pair**".
- 3 After the pairing is successful, tap "**Complete**", then back to main interface.
- 4 Tap "**Smart Blind**" icon on device page, you can see the details, such as Battery, History Records and etc. Follow the instructions to control Smart Blind.

Using Smart Blind Lite

Enable Alexa Skill:

After adding the Smart Blind Lite to your Third Reality Smart Hub, enable Third Reality Skill and tap "**DISCOVER DEVICES**" in your Alexa App, now you can use the voice assistant or to create routines in your Alexa App to control the Smart Blind.

Pairing with Hubitat

Website: <http://find.hubitat.com/>

Pairing Steps:

- ➊ Long press the setting button of blinds for more than 5 seconds the LED light flashes rapidly in red, indicating that the Smart Blind is in pairing mode.
- ➋ Log in the website, click "**Connect to Hub**".
- ➌ After pairing with Hub, choose "**Devices**", then click "**Discover Devices**", Tap "**Zigbee**", Choose "**Start Zigbee Pairing**".
- ➍ After the pairing is successful, it will shows on page as "**ThirdReality Smart Blind**". Click "**Label**" to rename the Smart Blind and then tap "**save**".
- ➎ Go to the Device page, you will see the Smart Blind and then click in, you will see the controlling buttons of "**Close**"、"**Open**"、"**Set Level**"、"**Pause**".

Troubleshooting

1 Factory Reset

Press and hold the setting "□" button of blinds for more than 5 seconds until the LED light flashes rapidly in red, indicating that the Smart Blind Lite is in pairing mode. Every time you factory reset the Smart Blind Lite, your preset bottom position will be reset to default(72"), you need to reset your desired bottom position.

2 Fail to pair with Echo

Make sure your Echo Speaker is compatible with Smart Blind Lite (including Echo (4th Gen), Echo Plus (1st Gen and 2nd Gen), Echo Show 10 (2nd Gen and 3rd Gen) and Echo Studio) and updated to the latest version.

- Please ensure your Echo devices are setup before adding the Smart Blind Lite.
- Reboot the Echo Speaker by unplugging the power and plugging it back in, then try to pair the Smart Blind Lite with it again.
- Factory reset the Echo Speaker (Press and hold the Action button for 25 seconds. The light ring will pulse orange, then turn off. Wait for the light ring to turn back on and turn blue. The light ring then turns orange again and the devices enters the setup mode), then try to pair the Smart Blind Lite with it again.

3 Smart Blind Lite is not responding after pairing with Echo device

- Check the LED indicator status of the Smart Blind Lite, blinking once every 3 seconds meaning it is offline, please reboot the Echo Speaker and factory reset the Smart Blind Lite, then pair the Smart Blind Lite with the Echo Speaker.
- If still not work, please try to deregister the Echo Speaker and register back in, then try to pair the Smart Blind Lite with it.

4 How to change the bottom position of the Smart Blind Lite

Press the UP button and let the Smart Blind Lite retract to the highest position, now the Smart Blind Lite returns to the original zero percent. Press the DOWN button to let the Smart Blind Lite extend, stop the bottom rail at your desired position by pressing the setting/stop button. Now hold up the bottom sensor with your finger first, then press the DOWN button, after that release the DOWN button first, then release the bottom sensor, now you have set this position as the preset bottom position, the Smart Blind Lite will stop at this position automatically next time when extending.

5 The "up" and "down" buttons of Smart Blind Lite reverse to the actual movement

When this happens, press the "Up" button and let the Smart Blind move to the lowest position. After it reaches the lowest position, it will continue moving to the highest position. Meanwhile, the "Up" and "Down" button will correspond with the actual direction of moving.

6 Press button no response after installation

Please confirm whether the batteries are installed correctly.

7 How to stop the Smart Blind Lite when it's extending/retracting?

You can stop the Smart Blind Lite from extending / retracting with a stop command of pressing the Stop button on the bottom rail or the remote, or in your Third Reality App.

You can not stop it from extending / retracting with commands like pressing Up / Down on the bottom rail or the remote(or in the App), nor with voice command like turn On / Off the first blind.

FCC Regulatory Conformance

This device complies with part 15 of the FCC rules. Operation is subject to the following two conditions: (1) this device may not cause harmful interference, and (2) this device must accept any interference received, including interference that may cause undesired operation.

Changes or modifications not expressly approved by the party responsible for compliance could void the user's authority to operate the equipment.

NOTE: This equipment has been tested and found to comply with the limits for a Class B digital device, pursuant to part 15 of the FCC Rules. These limits are designed to provide reasonable protection against harmful interference in a residential installation.

This equipment generates uses and can radiate radio frequency energy and, if not installed and used in accordance with the instructions, may cause harmful interference to radio communications. However, there is no guarantee that interference will not occur in a particular installation. If this equipment does cause harmful interference to radio or television reception, which can be determined by turning the equipment off and on, the user is encouraged to try to correct the interference by one or more of the following measures:

- Reorient or relocate the receiving antenna.
- Increase the separation between the equipment and receiver.
- Connect the equipment into an outlet on a circuit different from that to which the receiver is connected.
- Consult the dealer or an experienced radio/TV technician for help important announcement.

NOTE: The manufacturer is not responsible for any radio or TV interference caused by unauthorized modifications to this equipment. Such modifications could void the user's authority to operate the equipment.

RF Exposure

This equipment complies with FCC radiation exposure limits set forth for an uncontrolled environment.

This transmitter must not be co-located or operating in conjunction with any other antenna or transmitter.

Limited Warranty

For limited warranty, please visit

<https://3reality.com/faq-help-center/>.

For customer support, please contact us at

info@3reality.com or visit www.3reality.com.

For question on other platforms, visit for corresponding platform's application/support platforms.