

# Smart Switch Gen3 Starter Kit

## Matter supported via Smart Bridge MZ1

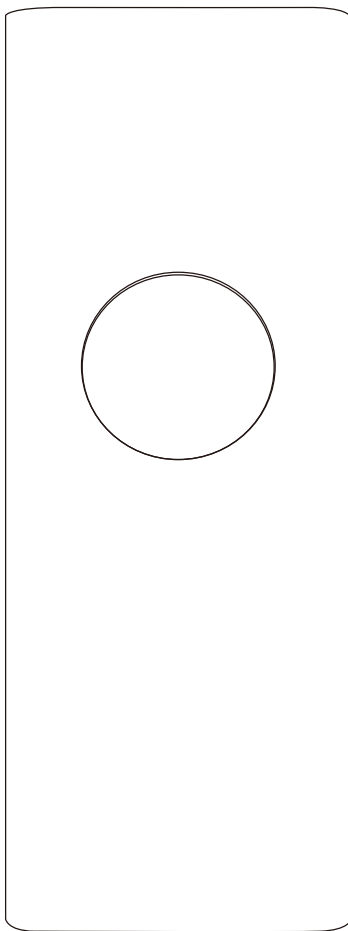

# Contents

Product Overview .....	01
What's in the Box .....	01
Smart Bridge LED Status .....	02
Smart Switch Gen3 LED Status .....	02
Setup .....	03
Update Firmware(Optional) .....	04
Matter Reset .....	05
Factory Reset .....	05
Setting up the Smart Switch Gen3 .....	06
Troubleshooting .....	09
Setup with 3R-Installer .....	10
Setup with Apple Home .....	14
Setup with Google Home .....	19
Setup with Alexa .....	24
Setup with SmartThings .....	29
FCC Regulatory Conformance .....	35
RF Exposure .....	36
Limited Warranty .....	36

# Product Overview

Elevate your smart home with the Motion Sensor Starter Kit. The Matter certified Smart Bridge MZ1 and the pre-connected Motion Sensor offer hassle-free setup and seamless integration with leading smart home platforms. Whether you're at home or on-the-go, it provides peace of mind by detecting movement and triggering alerts or automations.

## What's in the Box



Smart Bridge M1

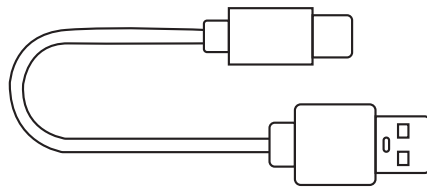

Power Cable



Pin

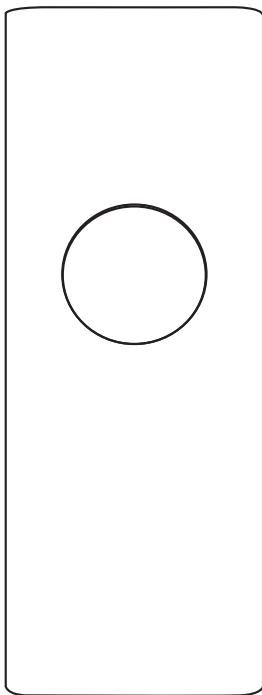

Smart Switch Gen3



1mm Spacers



2mm Spacers



3mm Spacers

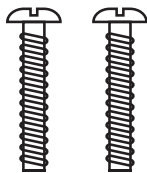

Screws

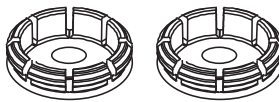

Fastener

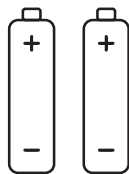

Batteries

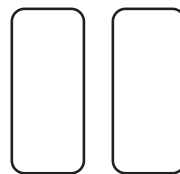

Protective Stickers

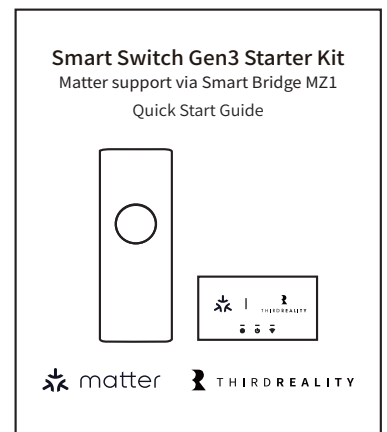

User Guide

# Smart Bridge LED Status

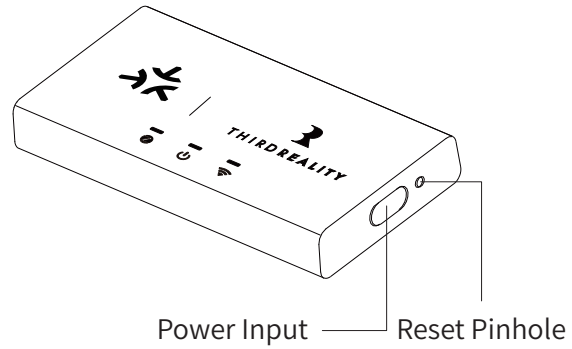
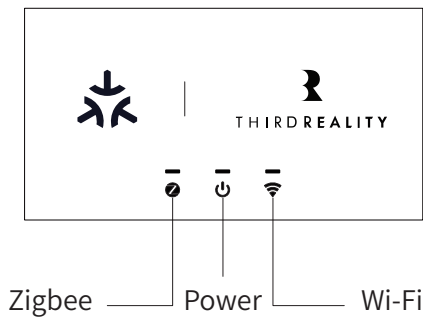

LED Status	Device Status
Zigbee LED slow blinking	Ready for Zigbee pairing
Wi-Fi LED fast blinking	Ready for Wi-Fi setup/Matter reset
Wi-Fi LED Off	Wi-Fi connection 15 min timeout
Wi-Fi LED On	Wi-Fi connected
Wi-Fi LED slow blinking	Wi-Fi connection lost/resuming
Power LED On	Power on
Power LED slow blinking	Device OTA in progress
All 3 LED fast blinking	Factory reset

\* Poke the pinhole of the Smart Bridge to start Zigbee pairing.

# Smart Switch Gen3 LED Status

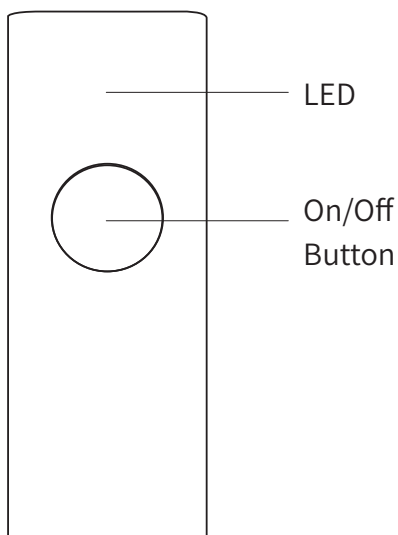

Device Status	LED Status
Low battery	LED double blinking
Pairing	LED fast blinking
Offline	LED slow blinking

Factory reset: Long press the on/off button for 30s.

# Setup

## 1. Prepare Your Smart Bridge

Please ensure that your phone and Matter controller are connected to the same 2.4GHz Wi-Fi network.

Power on the Smart Bridge with a power adapter (5V, 500mA). The Wi-Fi LED indicator will blink blue, indicating it is ready for Wi-Fi setup.

## 2. Configure Wi-Fi Network

Open your Matter controller app (Apple Home, Google Home, Alexa etc.), and follow the on-screen instructions to scan the QR code located on the Smart Bridge to set up Wi-Fi.

## 3. Power on the Smart Switch Gen3

Once the Wi-Fi setup is complete, power on your pre-connected Zigbee Smart Switch Gen3, and it will automatically connect to the Smart Bridge and add to your Matter controller app.

**Note:** The QR code on the Smart Bridge MZ1 is used for the setup process, while the QR code on the Smart Switch Gen3 does not serve a pairing function.

# Update Firmware (Optional)

Download and install the 3R-Installer App.

Enter the Smart Bridge MZ1 device page in your Matter controller App, tap Turn On Pairing Mode - Copy Code in Apple Home App/Linked Matter apps & services -Link apps & services- Use pairing code in Google Home App/Other Assistants and Apps - Add another in Alexa app, and copy the pairing code.

Open the 3R-Installer App, tap + in the up right - More Options, tap the Smart Bridge MZ1 and enter the Setup Code to add the Smart Bridge MZ1 in the 3R-Installer App.

The Smart Switch Gen3 connected to the Smart Bridge MZ1 will be discovered automatically in the 3R-Installer App.

Swipe to the right in the 3R-Installer App, and tap the device icon to enter the device page, tap Check Updates to update its firmware to the latest version.

## Matter Reset

Press the pinhole on the Smart Bridge 3 times quickly, it will be removed from the current connected Wi-Fi router, while all the connected Zigbee devices stay connected to the Smart Bridge MZ1. Then you can add the Smart Bridge MZ1 to another Matter controller, the connected Zigbee devices will be added automatically.

## Factory Reset

To factory reset the Smart Bridge, press and hold the reset pinhole for 5 seconds until all LED lights turn blue. Release the button, and the LED lights will turn solid blue, release the hold and the Wi-Fi LED light will blink blue, indicating it is ready for Wi-Fi setup.

To factory reset the Smart Switch, press the on/off button for 30 seconds until the LED light turns blue blinking, indicating it enters pairing mode.

Note: When you factory reset the Smart Bridge MZ1, the Smart Bridge will be removed from the Wi-Fi network, and all connected Zigbee devices will be removed from the Smart Bridge.

# Setting up the Smart Switch Gen3

Works with both toggle and rocker style switches.

1. Remove screws from faceplate.

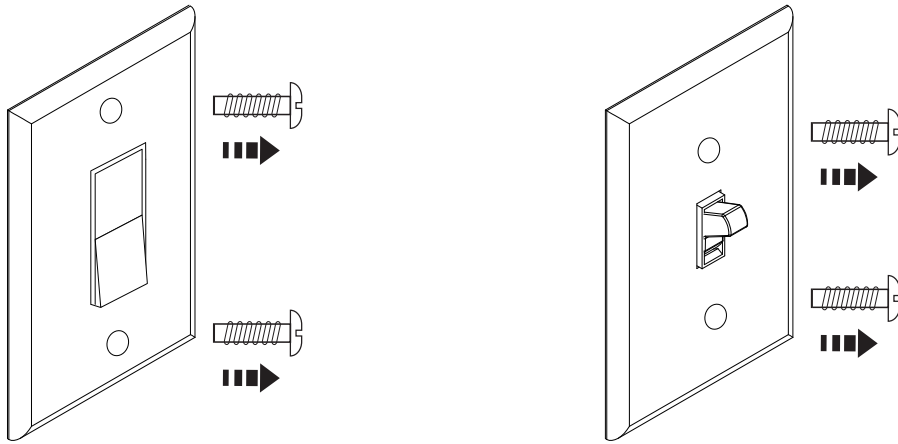

2. For rocker switch, please select the fasteners and spacers as shown below. Start with the appropriate spacers. When you get to Step7, you may need to adjust the spacers accordingly.

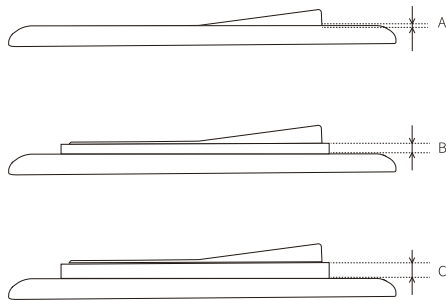

A: -0.5mm~1mm	No Spacer
B: 1mm~2.5mm	Thin Spacer
C: 2.5mm~4mm	Thick Spacer

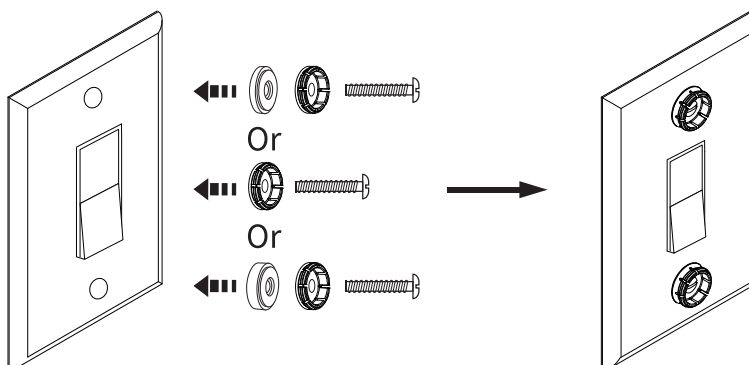

3. Insert two AAA batteries and replace cover.

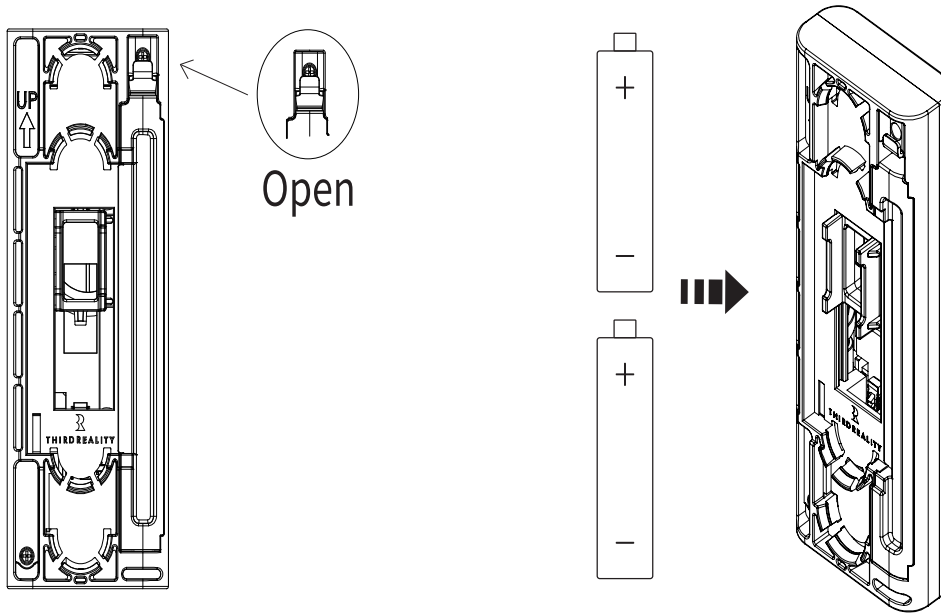

4. Make sure Smart Switch actuator is in the up position by pressing the button.

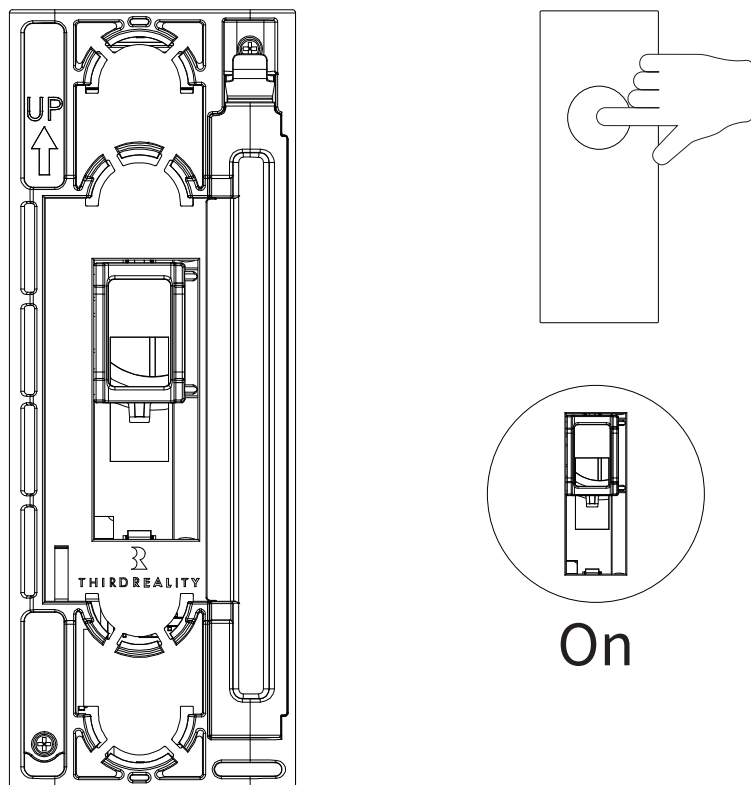

5. Turn your rocker or toggle switch ON position, as shown.

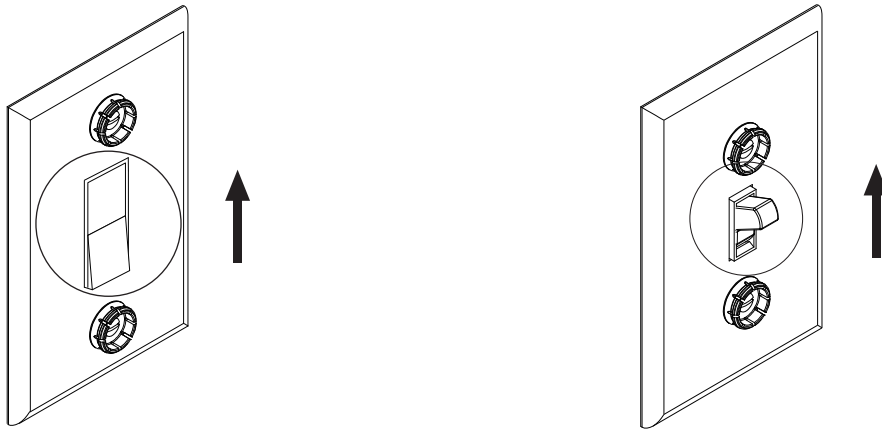

6. Place Smart Switch over existing switch. Test the switch by pressing the button to turn on and off. Adjust the spacers to ensure proper engagement between the Smart Switch and wall switch.

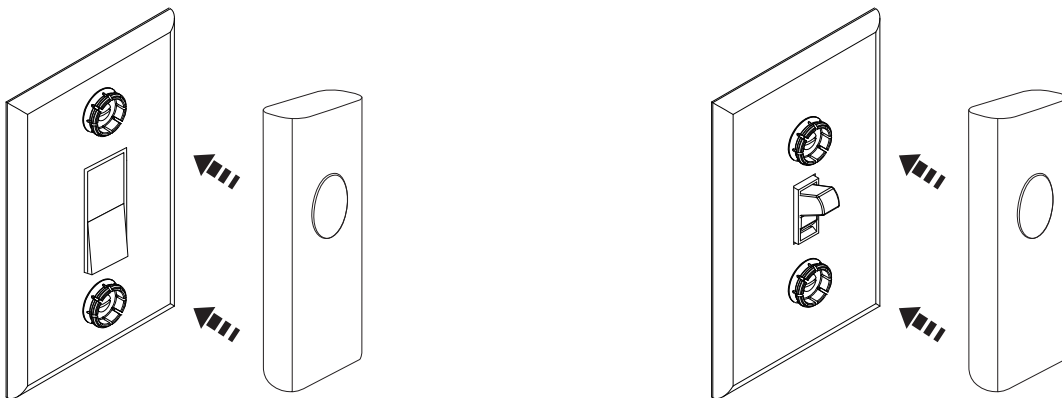

Optional-For rocker switch, place protective film over paddle.

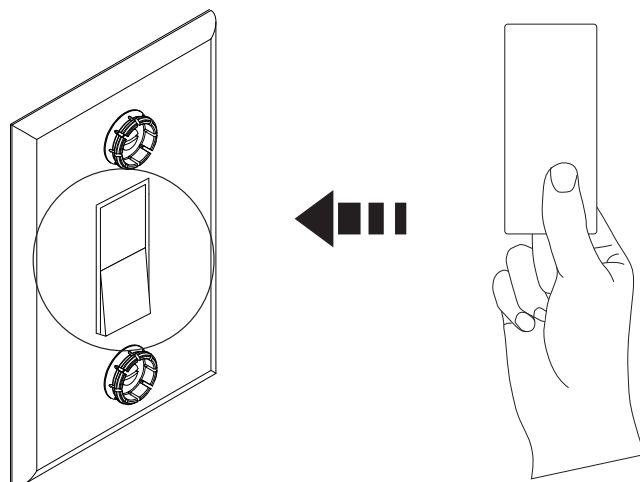

# Troubleshooting

**Q:** The Smart Bridge MZ1 cannot be added in 3R-Installer App, or my Matter controller App.

**A:** Reboot your phone, kill the Matter controller app and try to set up the Smart Bridge MZ1 again.

When paired with a Matter controller/speak, ensure both your phone and your Matter controller/speaker stay connected to the same 2.4GHz Wi-Fi network.

Make sure your Wi-Fi router does not automatically change to 5 GHz automatically by banning it temporarily, and your Matter controller does not switch to another Wi-Fi router automatically.

**Q:** No smart switch found after adding the smart bridge.

**A:** Place the Smart Switch Gen3 near the Smart Bridge.

Press and hold the on/off button of the switch for 30 seconds until the LED light turns blue blinking, indicating it enters pairing mode.

Press the pinhole of the Smart Bridge and the Zigbee LED light turns blue blinking, indicating it enters Zigbee pairing mode.

The switch will be paired to the Smart bridge within seconds.

# Setup with 3R-Installer

This Matter certified bridge can be paired to any Matter certified ecosystems.



Compatibility:

iOS system: Version 1.0.2 or later.

1. Download and install the 3R-Installer App(iOS/Android) on your phone.
2. Make sure your phone has a stable internet access through 2.4GHz Wi-Fi network.
3. Power on the Smart Bridge with the power adaptor, the Wi-Fi LED indicator is in blue blinking, indicating it is ready for Wi-Fi setup.
4. Open the 3R-Installer App on your phone and tap + in the upper right corner.

5. Scan the Matter QR Code on the smart bridge and follow the on-screen instructions to configure the Wi-Fi network.
6. After the Wi-Fi network configuration is completed and the Zigbee end device is powered up, you can find the smart bridge and pre-connected Zigbee devices on the device page.
7. Open the 3R-Installer App, swipe to the right to check the devices connected to the bridge, tap the device icon to enter the device page, you can Check Updates for firmware OTA for the device.
8. Tab Link With Matter Enabled Services, copy the Manual Setup Code or Scan the QR Code within 3 min, then you can add the bridge to other Matter supported ecosystems through multi-admin.

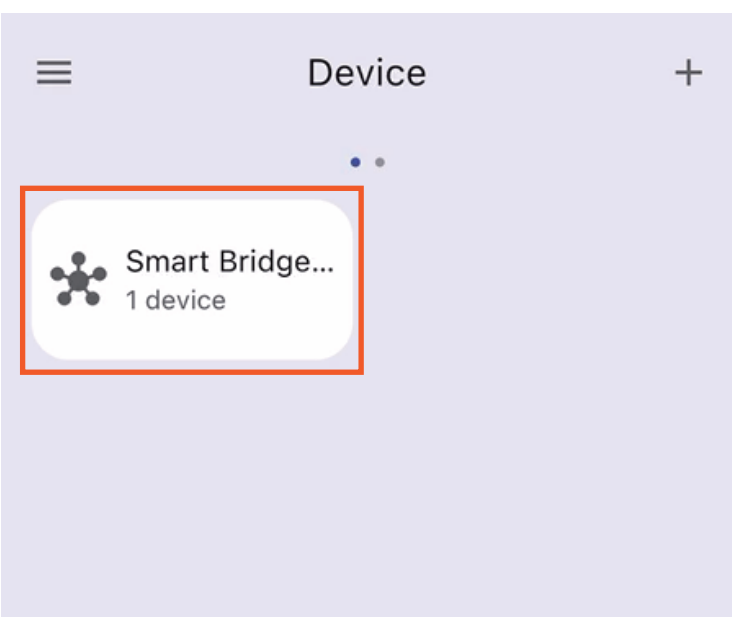
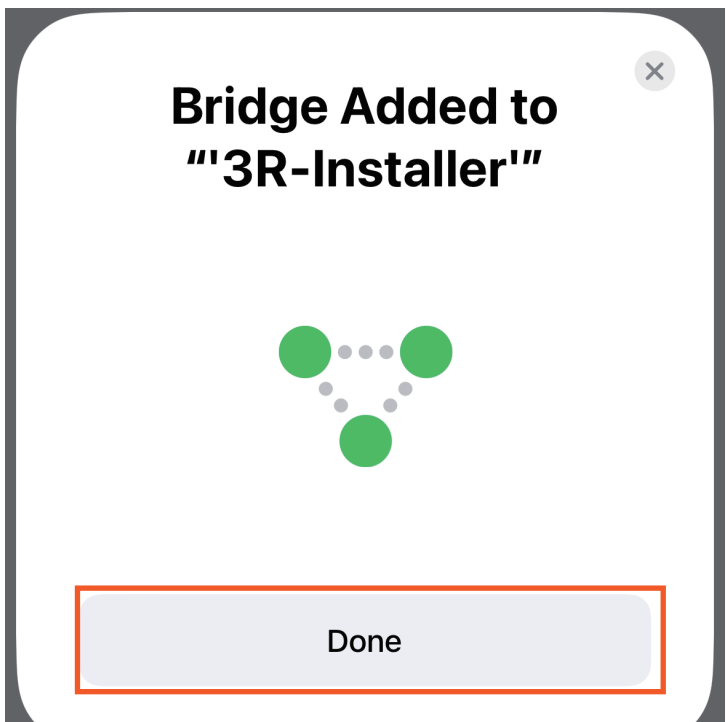
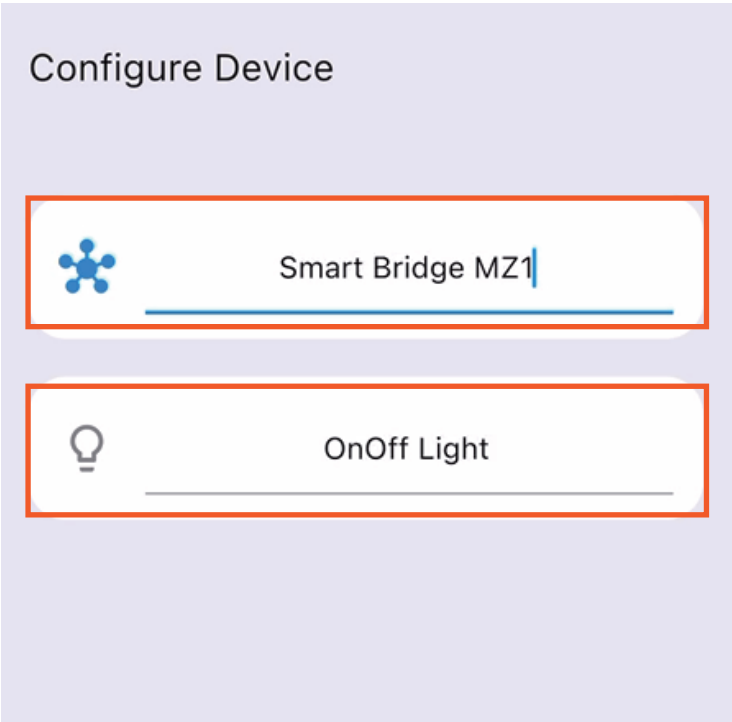
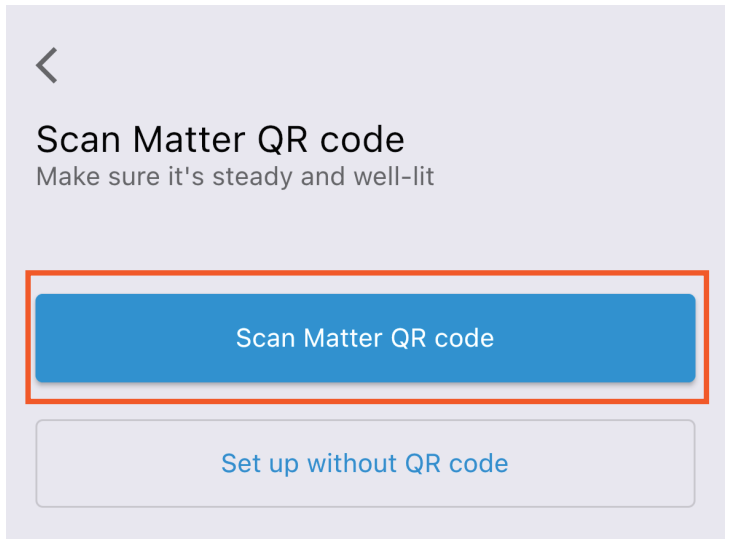
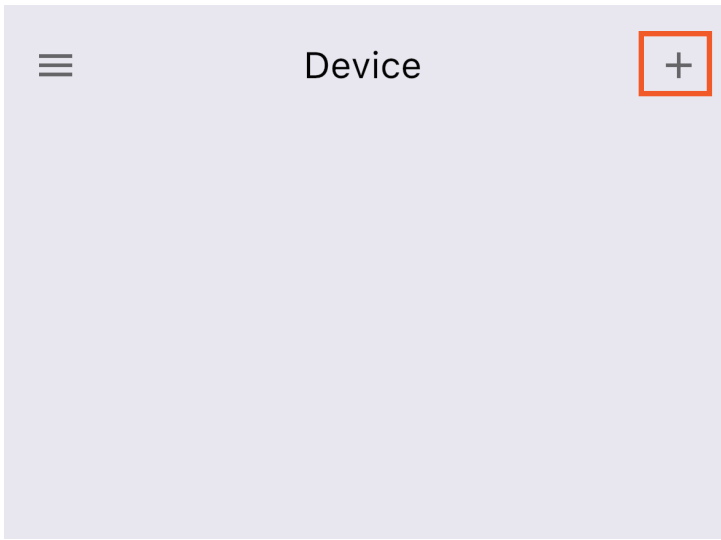

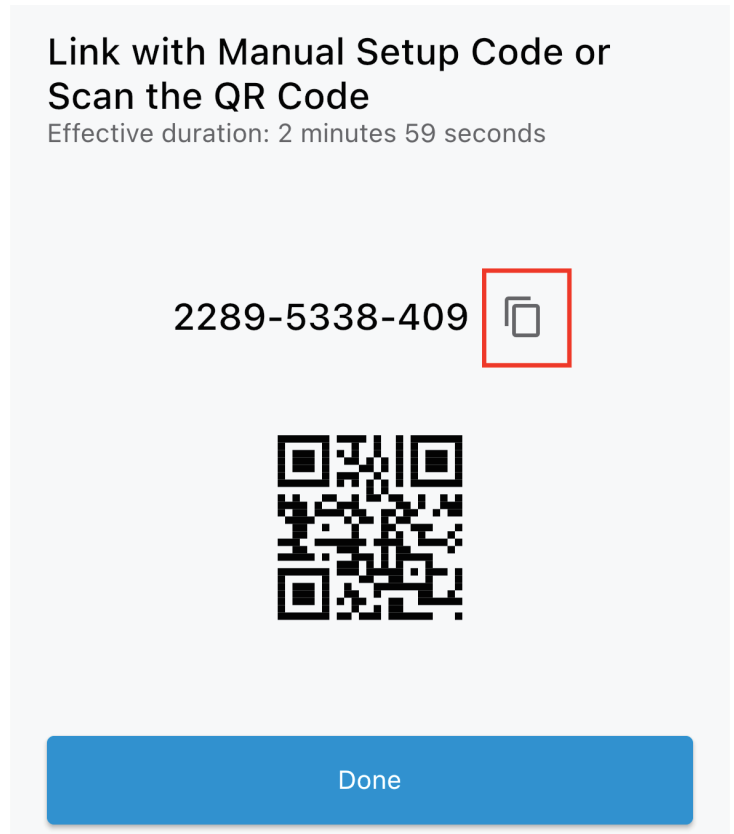
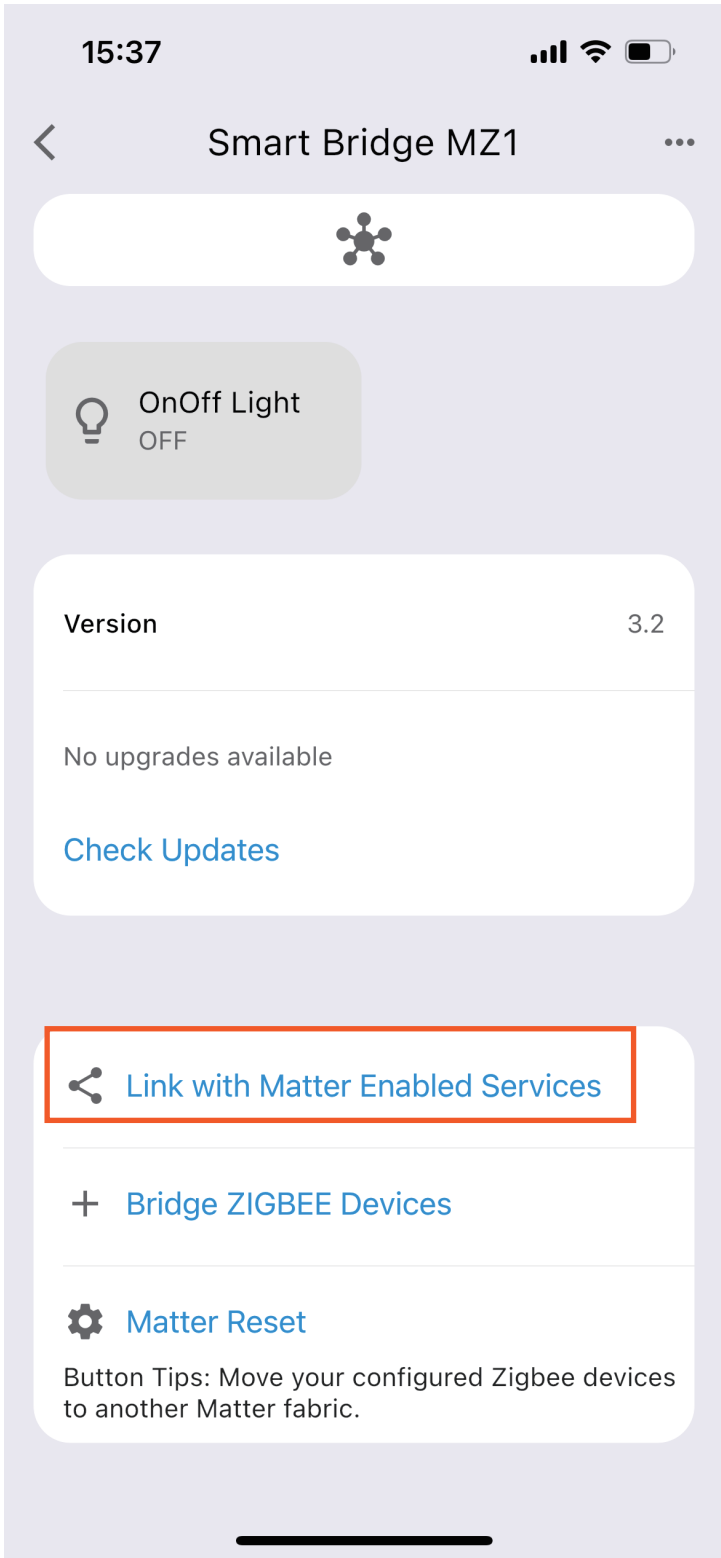

# Setup with Apple Home



Compatibility:

iOS system: Version 16.6 or later.

Matter-supported Controller: Home Pod, Home Pod mini, or Apple TV.

**Note:** It is highly recommended to download and install 3R-Installer app on your phone first, follow the instructions below to setup the bridge in the 3R-Installer app, then get the setup code and add the bridge to your Apple Home through multi-admin. You can also Scan the QR code to add the bridge to your Apple Home directly.

1. Setup the smart bridge with 3R-Installer App, copy the Setup code of the smart bridge in 3R-Installer App.(Code effective duration: 3 min)
2. Make sure your Apple Home Controller is connected to the same Wi-Fi network, launch your Home App. Tap **+** and then tap **Add or Scan Accessory** to add a new device. Tap **More Options**, Select the Smart Bridge MZ1 to Add device, paste the Setup Code copied from 3R-Installer App to Continue, set the location and name for the bridge, the bridge will be added to My Home.
3. Pre-connected accessories attached to the Smart Bridge will be automatically updated.

4. Set location and name for the accessories, then create automation for the accessories.
5. To connect the device to another Matter certified ecosystem app, long press any attached accessories and tap [Accessory Settings](#) to enter accessory page, tap Bridge to enter the Smart Bridge MZ1 device page, tap [Turn On Pairing Mode](#) to generate and copy a new setup code. Launch the app of another Matter certified ecosystem, follow the setup instruction to paste the setup code and follow the app instructions to complete the setup.

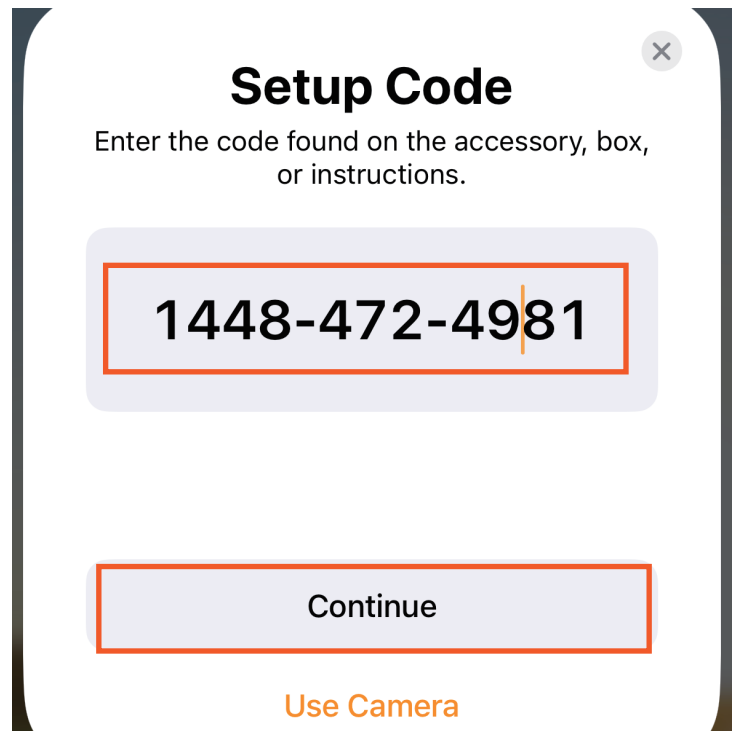
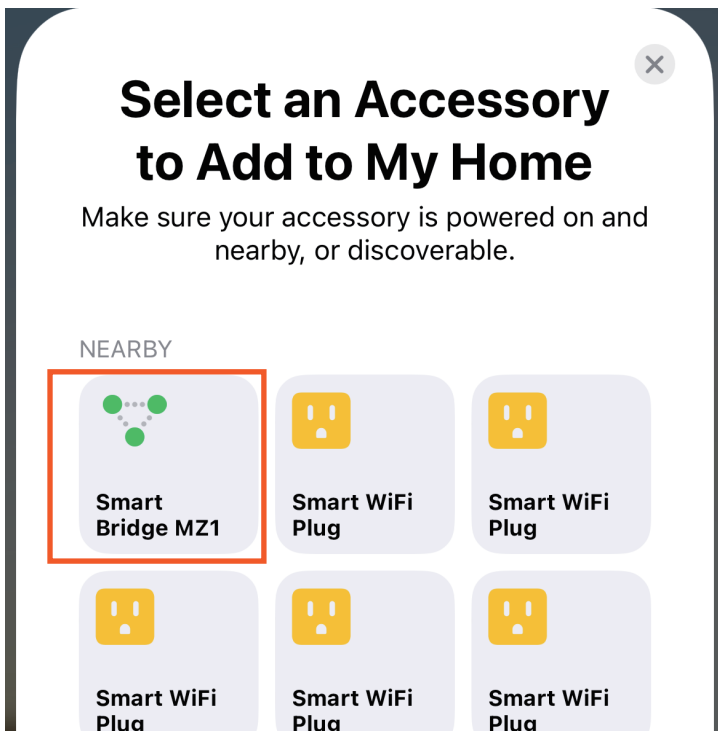
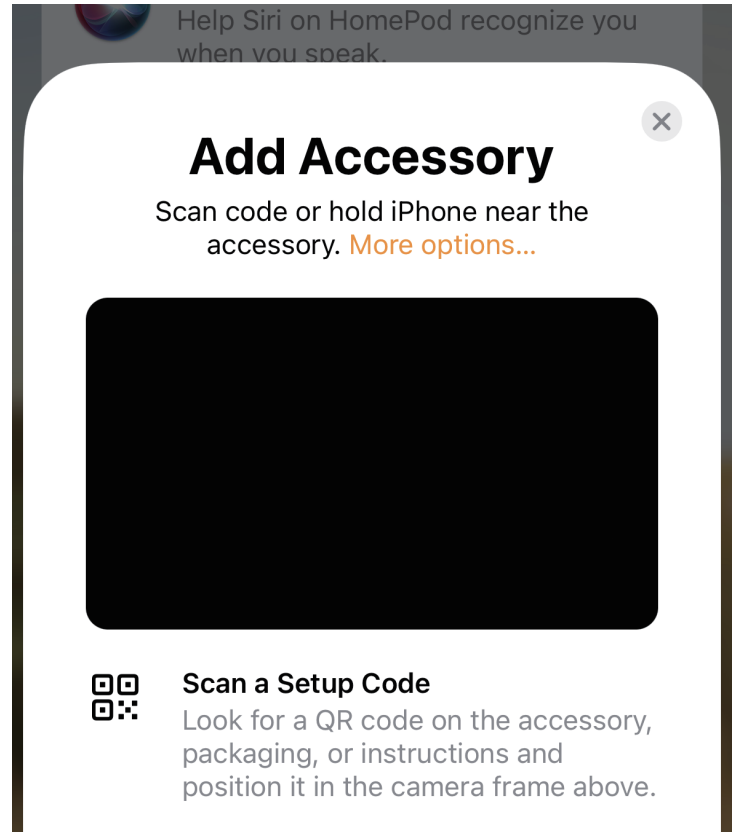
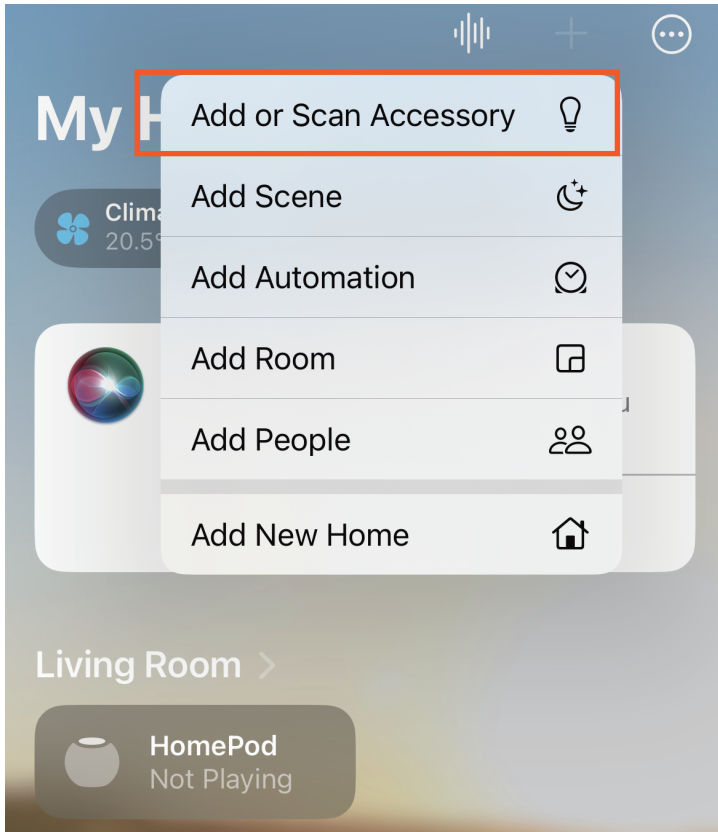

## Bridge Location



Living Room

Bedroom (Suggested)

Dining Room (Suggested)

Kitchen (Suggested)

Continue

## Bridge Name



Use the name provided or enter a custom name.

Smart Bridge MZ1



Continue

## Bridge Added to My Home



Continue

## OnOff Light



This light is connected to Smart Bridge MZ1.



Continue

## Light Location



Living Room

Bedroom (Suggested)

Dining Room (Suggested)

Kitchen (Suggested)

Continue

## Light Name



Use the name provided or enter a custom name.

OnOff Light



Continue

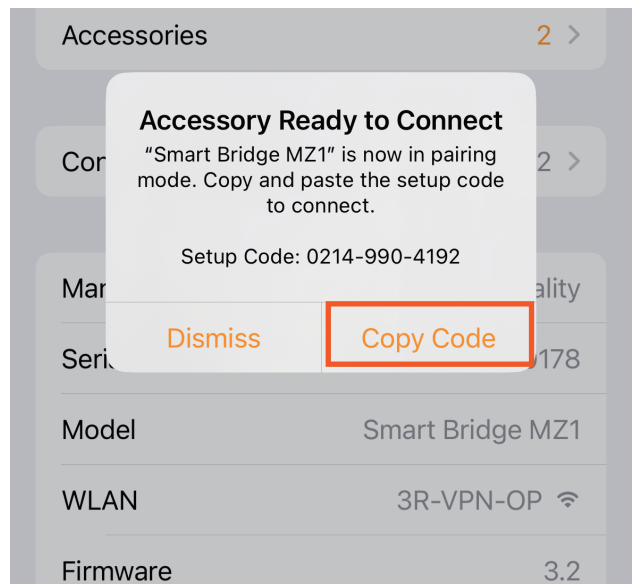
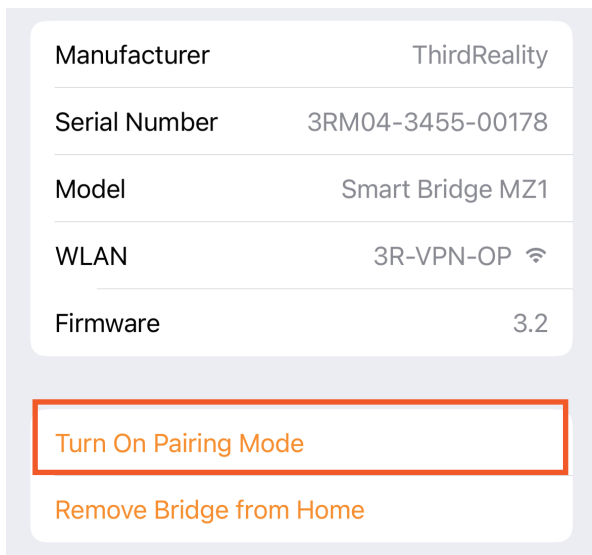
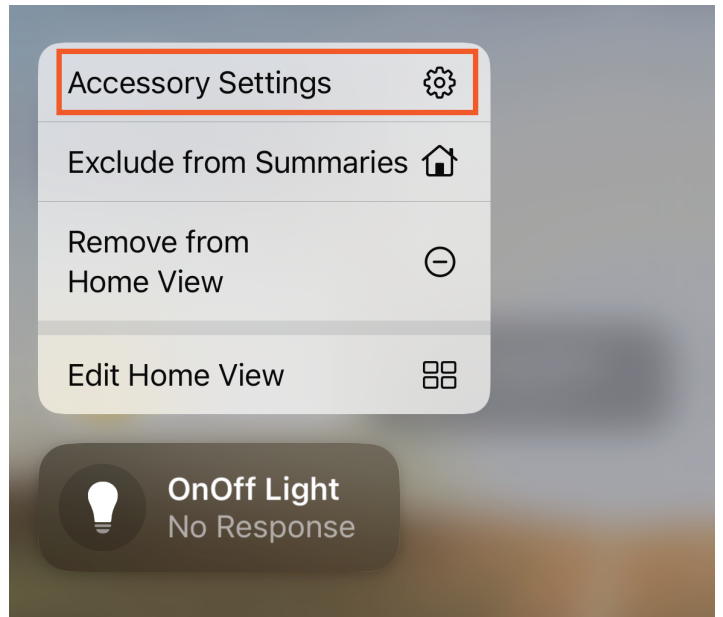
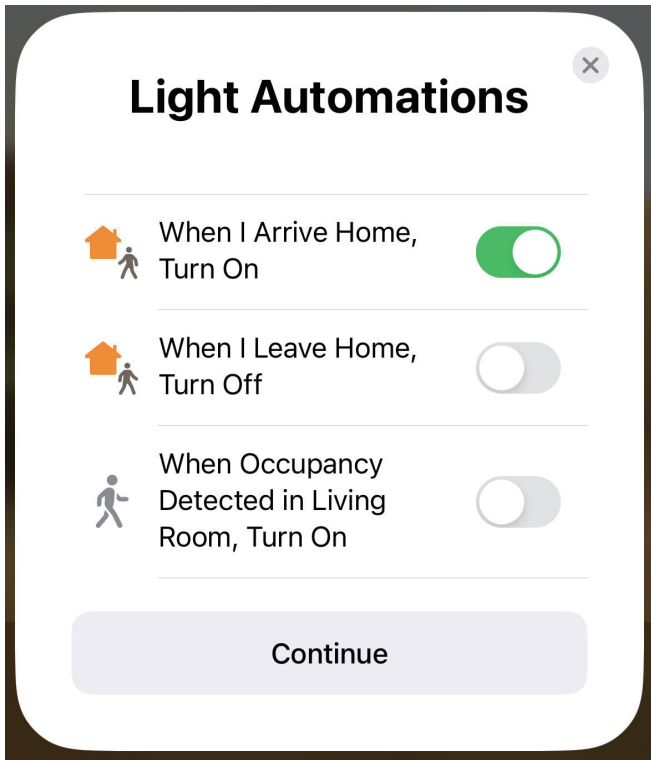

# Setup with Google Home



## Compatibility

Google Home App version:

Android: 3.3.1.4 or later

IOS: 3.3.104 or later

**Note:** It is highly recommended to download and install 3R-Installer app on your phone first, follow the instructions below to setup the bridge in the 3R-Installer app, then get the setup code and add the bridge to your Apple Home through multi-admin. You can also Scan the QR code to add the bridge to your Apple Home directly.

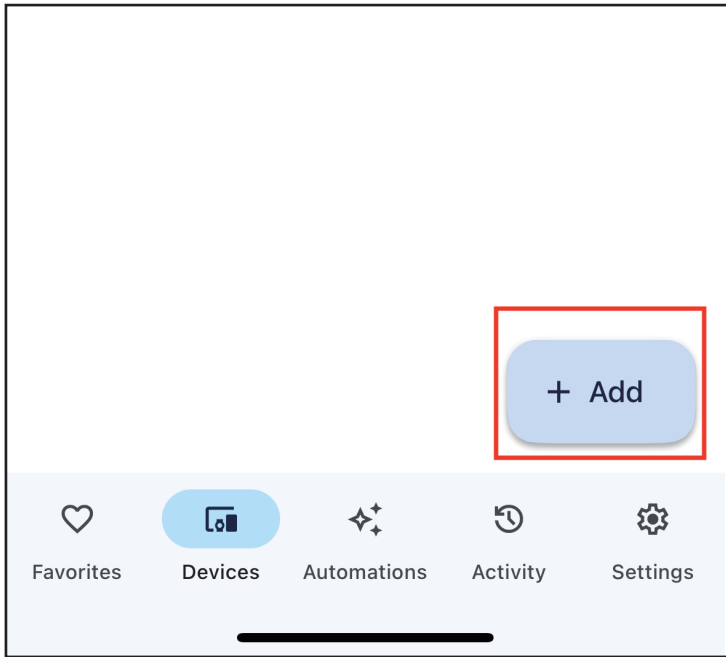

1. Setup the smart bridge with 3R-Installer App, copy the Setup code of the smart bridge in 3R-Installer App.(Code effective duration: 3 min)
2. Make sure your Google Home speaker is connected to the same Wi-Fi network, launch your Google Home App. Tap **+** and then tap **New device**. Choose a home and tap Next, choose the smart bridge then tap **Next**, **Continue** without scanning, paste the Setup Code to Continue, create a name for the bridge, the bridge will be added.

3. Pre-connected devices attached to the smart bridge will be automatically updated.
4. Create names and add the devices to Google Home, then create automation for the devices.
5. To connect the device to another Matter certified ecosystem app, long press any attached accessories and tap Accessory Settings to enter accessory page, tap Bridge to enter the Smart Bridge MZ1 device page, tap Turn On Pairing Mode to generate and copy a new setup code. Launch the app of another Matter certified ecosystem, follow the setup instruction to paste the setup code and follow the app instructions to complete the setup.









## Set up a device

Set up a new device or add an existing device or service to your home

-  **New device**  
Add a Chromecast, Google Nest speaker or display, Nest Wifi, a Matter-enabled device, or a partner device, including those labeled "Seamless Setup with the Google Home App."
-  **Works with Google**  
Link one of your existing devices or services, like connected light bulbs or plugs.



## Nearby devices

Choose the device you would like to set up

-  **Nest Hub Max**  
Basement display
- 
-  **Matter Plug**  
Matter Plug
-  **Matter Plug**  
Matter Plug
-  **Matter Plug**  
Matter Plug
-  **Matter Plug**  
Matter Plug
-  **Matter Plug**  
Matter Plug

[Not Now](#) [Next](#)

## Connect this device to your Google Account

-  This lets you control your device with Google Assistant or the Google Home app.
-  The device shares information with Google, like its current state (on or off, for example).
-  Google may make firmware updates available when firmware updates are provided by your device manufacturer. For debugging and product improvement, Google may share aggregate device usage data and de-identified diagnostic data with the device manufacturer.

Information shared with Google will be processed in accordance with [Google's Privacy Policy](#). You can remove this connection anytime in Settings.

[Cancel](#) [I agree](#)

## Bridge

"Google Home" would like to add this accessory to "Google Home".



This accessory will be added to "Google Home" and stored in your keychain so you can add it to additional connected services.

Add to "Google Home"

## Enter Matter pairing code

The 11- or 21-digit pairing code may be on the device. If not, you can set up with the manufacturer.

14107851637

Exit

Next

## Bridge

"Google Home" would like to add this accessory to "Google Home".



This accessory will be added to "Google Home" and stored in your keychain so you can add it to additional connected services.

Add to "Google Home"

## Accessory Name

Use the name provided or enter a custom name.

Accessory

Continue

## Accessory Added to "Google Home"



Done

## Device connected



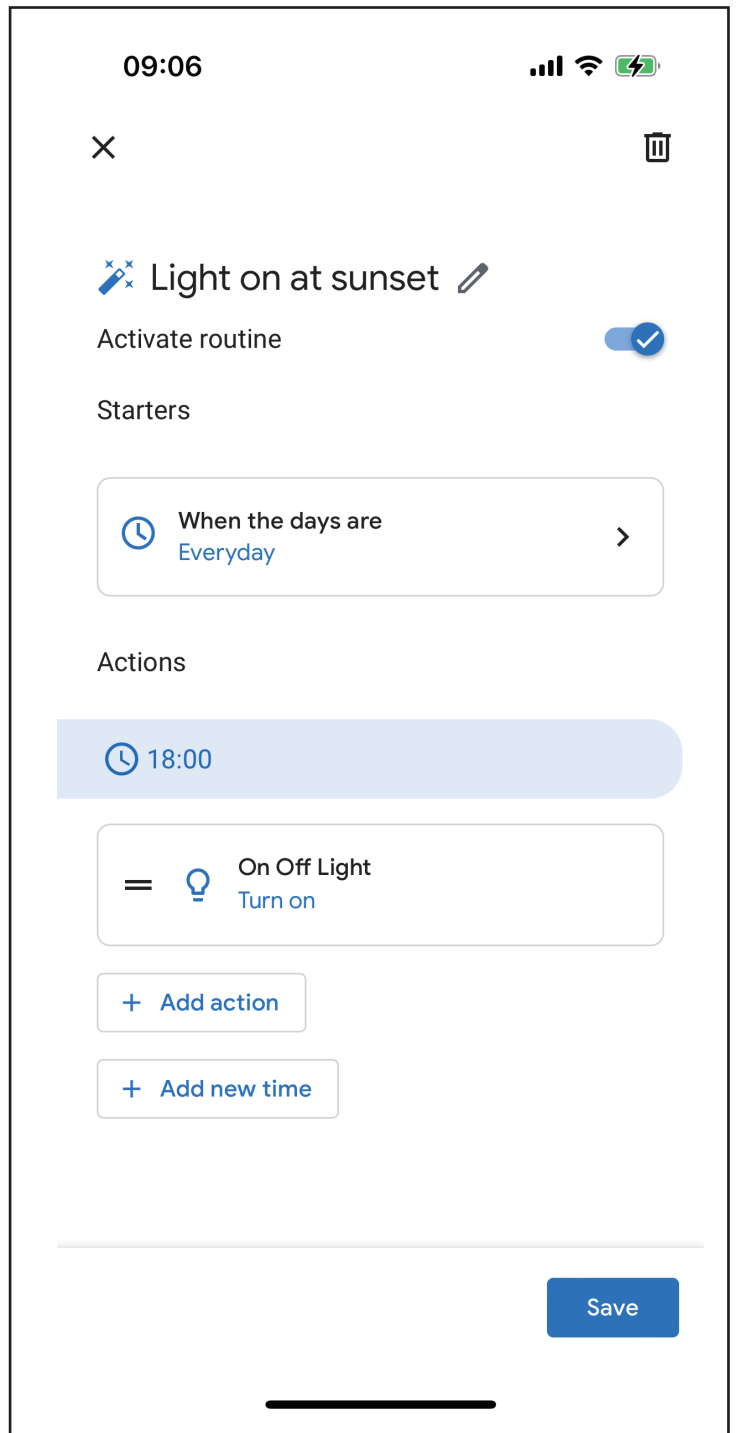
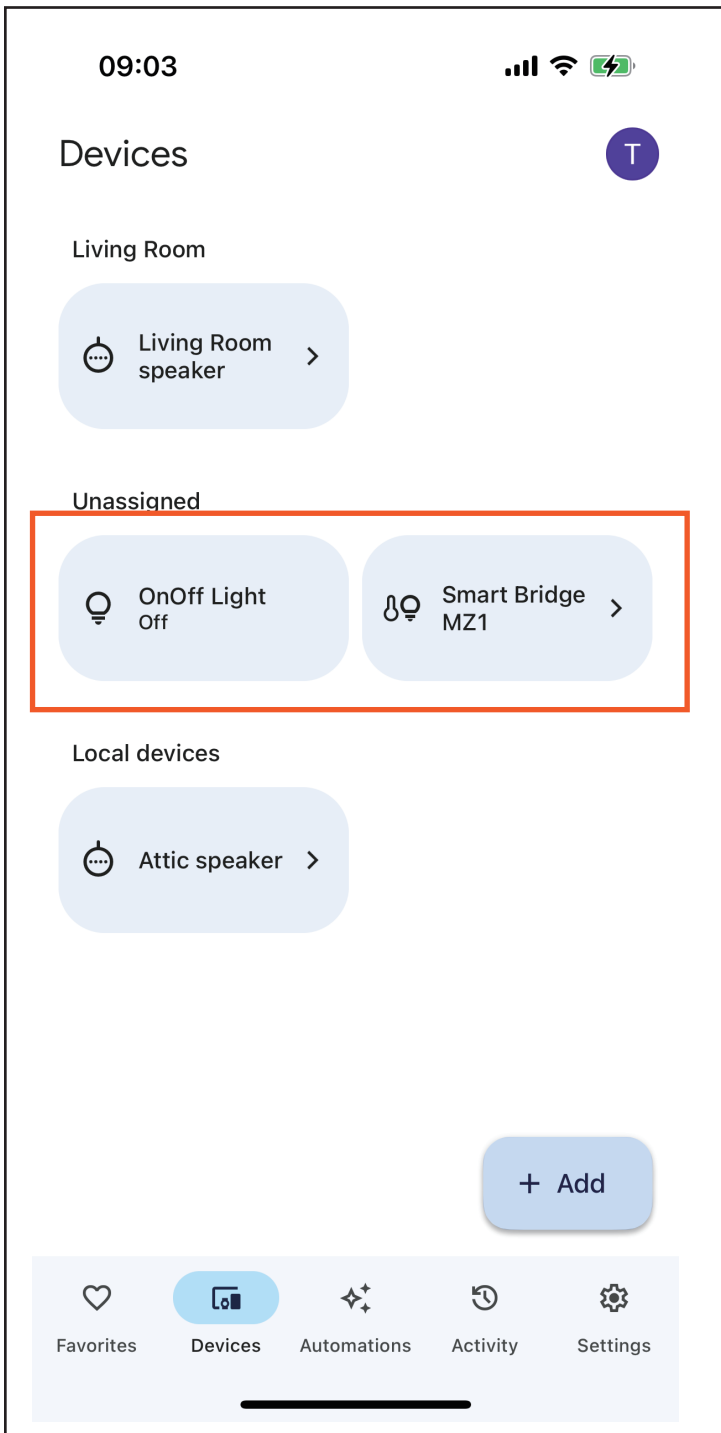

# Setup with Alexa



Alexa App version:

Android: 2.2.521848.0 or later for build version, and 2023.15 or later for APP version

IOS: 2.2.548660 or later for build version, and 2023.15 or later for APP version

**Note:** It is highly recommended to download and install 3R-Installer app on your phone first, follow the instructions below to setup the bridge in the 3R-Installer app, then get the setup code and add the bridge to your Alexa through multi-admin. You can also Scan the QR code to add the bridge to your Alexa directly.

1. Setup the smart bridge with 3R-Installer App, copy the Setup code of the smart bridge in 3R-Installer App. (Code effective duration: 3 min)
2. Make sure your Alexa speaker is connected to the same Wi-Fi network, launch your Amazon Alexa App, tap **+** in the up right on the device page to **Add Device**, scroll down the the list and tap **Other**, choose matter, **TRY MUMERIC CODE INSTEAD** to **ENTER CODE**, and follow the instructions to add the bridge and pre-connected devices.
3. Create routines with the devices.

4. To connect the device to another Matter certified ecosystem app, go to the app of the first ecosystem to generate a new setup code. Go to the Device Settings page, tap **Other assistants and apps** and **Add another**, then copy the setup code. Launch the app of another Matter certified ecosystem, follow the setup instruction to enter the setup code and follow the app instructions to complete the setup.

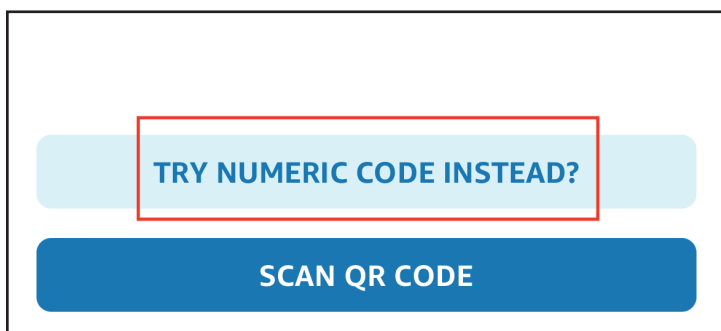
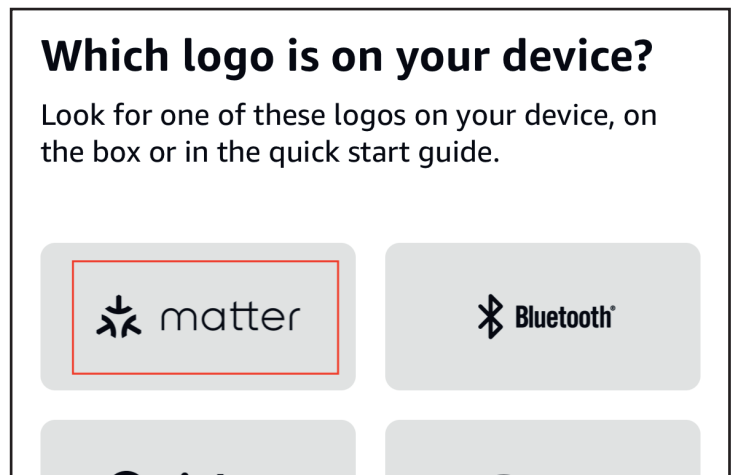
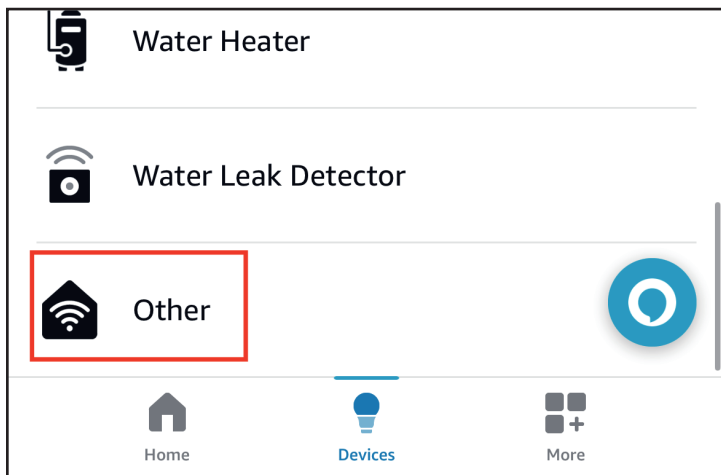
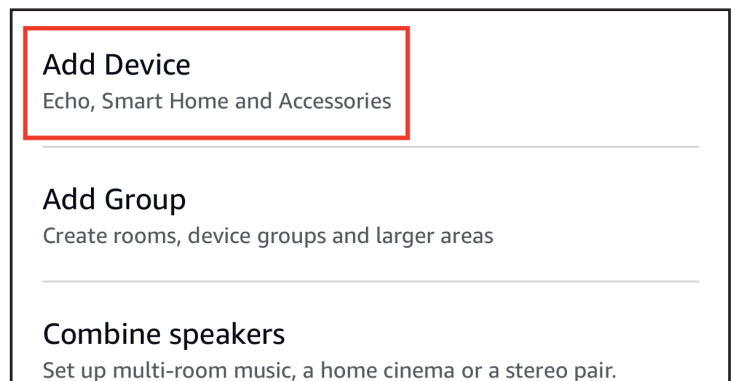
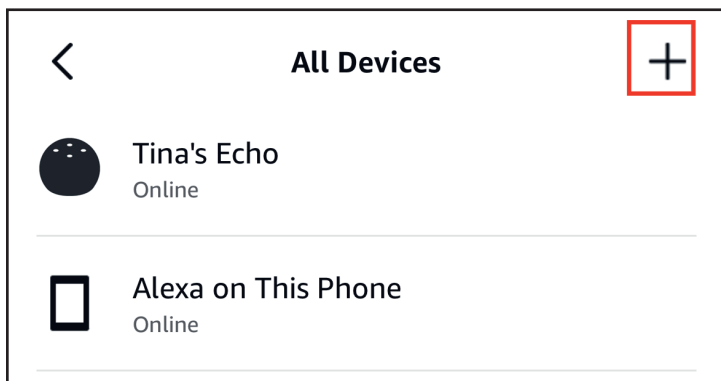

## Enter numeric code

You can find it inside the device's box, in the quick-start guide or on the device.

Numeric code  
14820824517

Please enter 11- or 21-digit code

SCAN QR CODE?

NEXT



TIME SENSITIVE

now

**Accessory Added to Amazon Alexa**  
Your Smart Bridge MZ1 Bridge has been added to your home.



## Alexa is getting your device ready

This may take up to a minute



## ThirdReality Hub and 2 devices found and connected

These devices have been added to your Alexa account. Next, continue setting up each of these devices one at a time.

Next

**Devices** +

**Groups**

Bedroom Living room New Group

**Devices**

- OnOff Light  
• Recently added
Off
- Smart Bridge MZ1
- Tina's Echo  
Online

**OnOff Light** ⚙️



Power is Off

Create a Routine

  
Home

  
Devices

  
More

Cancel **New Routine**

light on At sunset Rename

**WHEN**

🕒 At sunset  
Every Day
⊖

Add another event +

**ALEXA WILL**

⊞ 🏠 OnOff Light  
Power: On
⊖

Add another action +

Settings 

## Smart Bridge MZ1

[Edit Name](#)

---

**Other assistants and apps**  
Change which other assistants and apps can control the device.

**About**

**Connected Via**  
Tina's Echo

---

**Description**  
ThirdReality smart device

Settings 

## Other assistants and apps

This device can be controlled with other assistants and apps.

[Add another](#) 

Connect an app 

## Control device with another assistant or app

Copy the code and enter it in the app you want to use to control this device. [Learn more](#)

**0253-423-3528**



[Copy](#)

Code expires in 14:57

Cancel **New Routine**



## light on At sunset [Rename](#)

**WHEN**

 At sunset   
Every Day

[Add another event](#) 

**ALEXA WILL**

  OnOff Light   
Power: On

[Add another action](#) 

# Setup with SmartThings

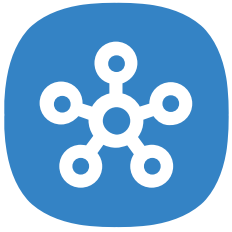

## Compatibility:

SmartThings App version 1.8.01.22 or higher. iOS SmartThings App version 1.7.02.16

Matter-supported Controller: SmartThings Hub V2& V3, Aeotec Smart Home Hub

1. Setup the smart bridge with 3R-Installer App, copy the Setup code of the smart bridge in 3R-Installer App. (Code effective duration: 3 min)
2. Make sure your SmartThings hub is connected to the same Wi-Fi network, launch your SmartThings App. Tap + to add Partner device, choose Matter, then Add without QR code, enter the numeric code copied from 3R-Installer app, tap Next and follow the on-screen instructions to add the bridge and pre-paired devices.
3. Create routine with the Zigbee devices added through the smart bridge.
4. Press the reset button through the pinhole with a pin to enable Zigbee pairing, the Zigbee LED indicator of the smart bridge turns into blue blinking, put THIRDREALITY Zigbee devices into pairing mode to add devices.

- To connect the device to another Matter certified ecosystem app, go to the app of the first ecosystem to generate a new setup code. Go to the Device Settings page, tap Share with other services then Share device, there will be QR code and a numeric code. Launch the app of another Matter certified ecosystem, follow the setup instruction to enter the setup code and follow the app instructions to complete the setup.

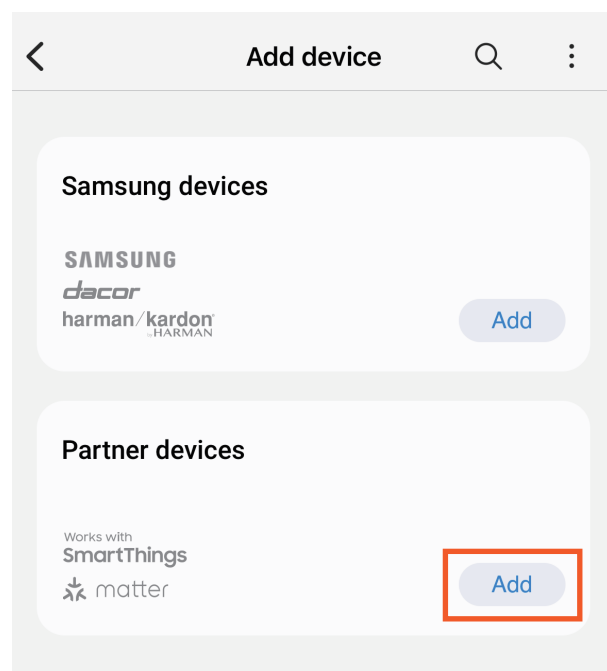
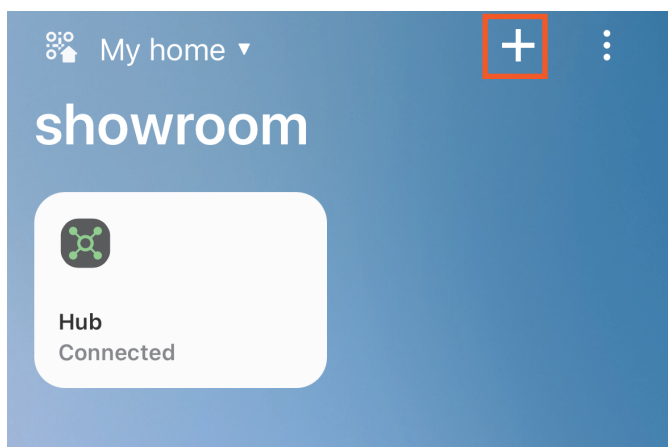

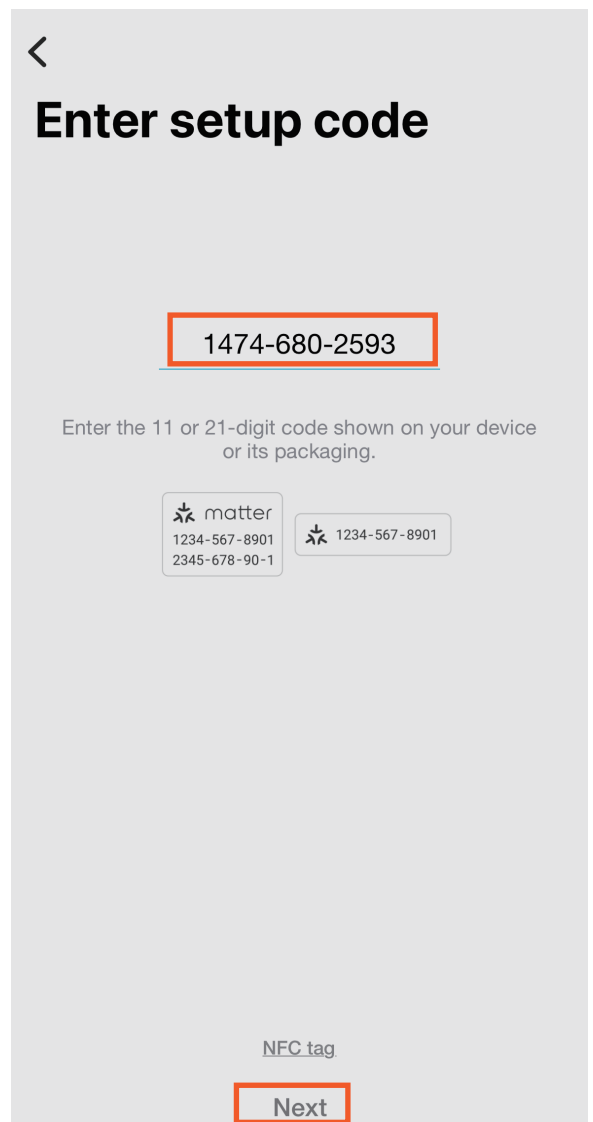
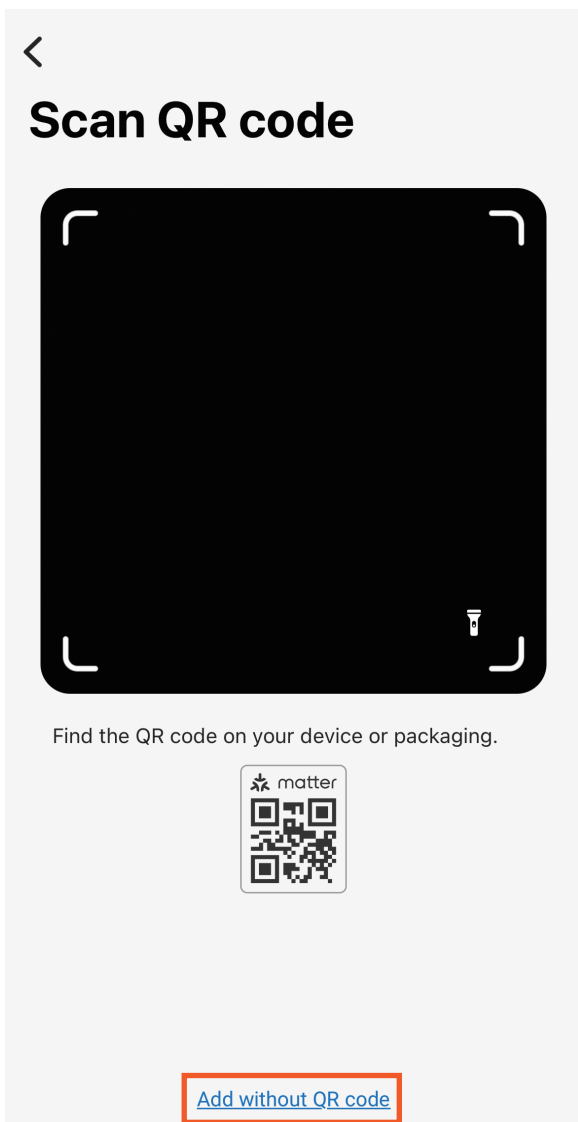
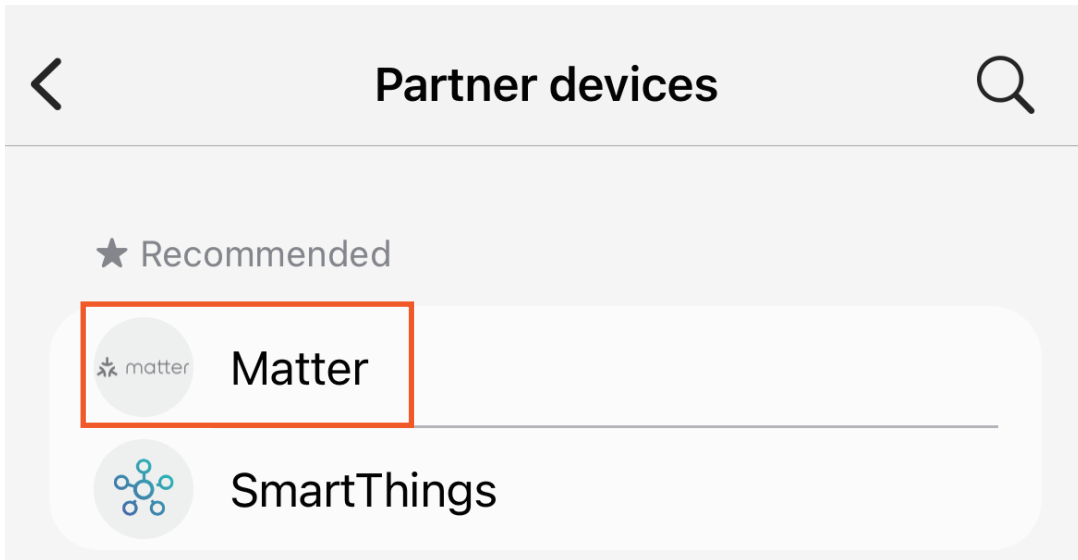

**Accessory** ✕

"SmartThings" would like to add this accessory to "iCloud Account".



This accessory will be added to "iCloud Account" and stored in your keychain so you can add it to additional connected services.

**Add to "iCloud Account"**

**Accessory Name** ✕

Use the name provided or enter a custom name.

Accessory ✕

**Continue**

**Accessory Added to "iCloud Account"** ✕



**Done**

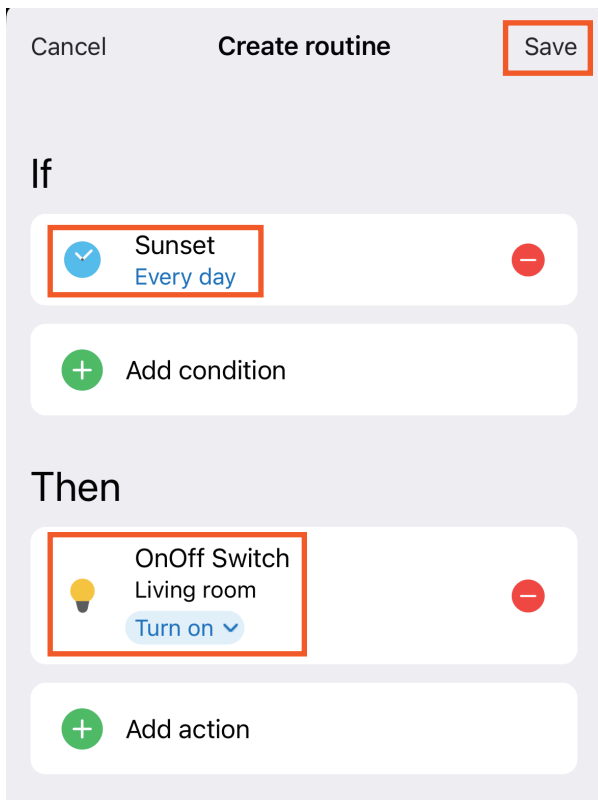
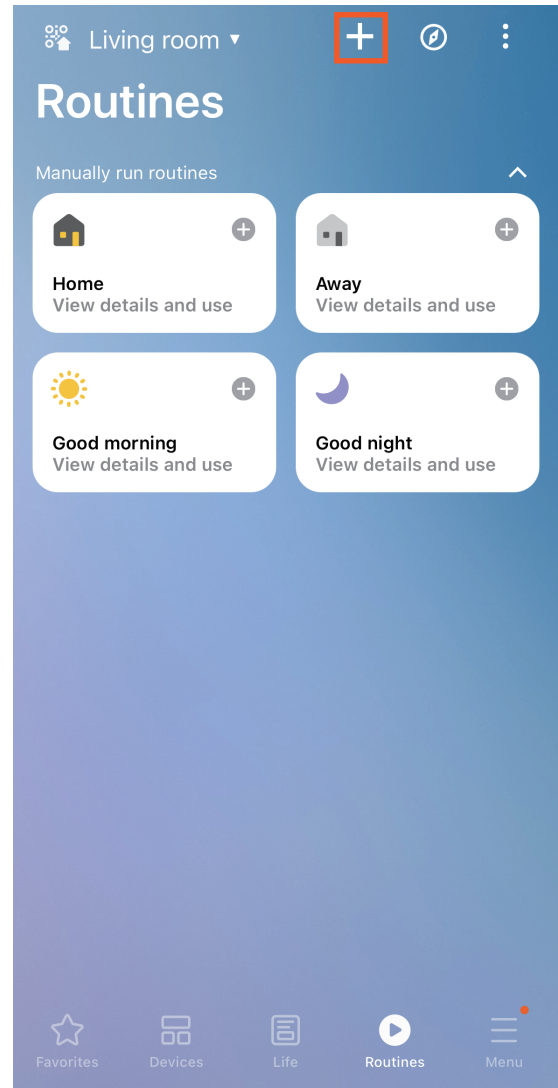
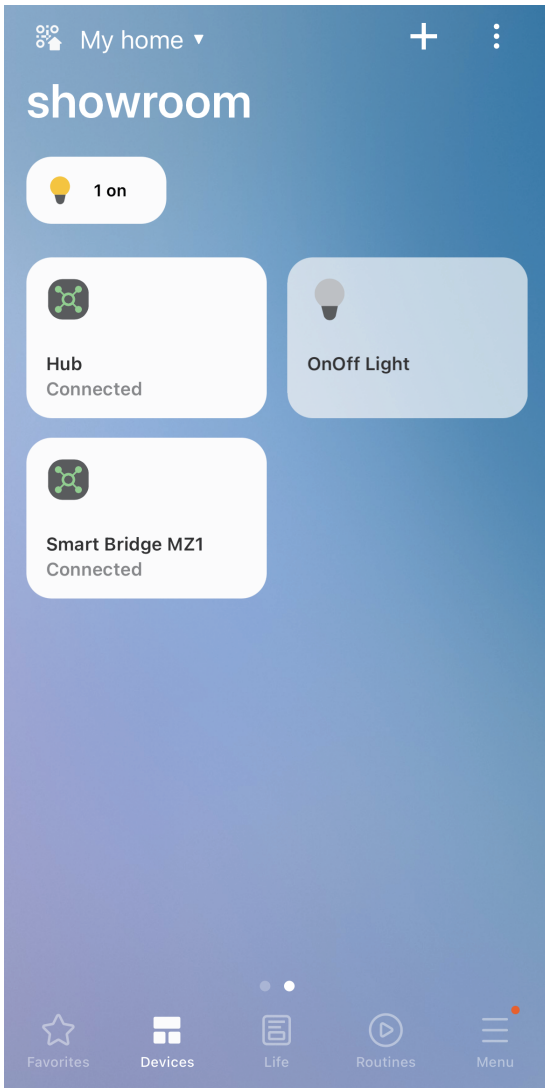

Smart Bridge MZ1 settings

General

Name  
Smart Bridge MZ1

Home  
Home

Room

**Linked Matter apps & services**  
Can control and manage this device

Technical information  
Wi-Fi, model, versions, more

Remove device

## Linked Matter apps & services

You can control and manage this device with these Matter-enabled apps & services

[Link apps & services](#)

Linked apps & services (3)

Vendor ID: 1384	×
Vendor ID: 1407	×
Vendor ID: 6006 Android, Google Home, Google Assistant	×

[Unlink all Matter apps & services from this device](#)

When you unlink a Matter app or service, you can no longer use it with this device. Other connection types might still have access.

### Use pairing code to link

Copy this code, open a Matter-enabled app, and enter the code when prompted. This code expires in 15 minutes.

32173417346

[Copy pairing code](#)

# FCC Regulatory Conformance

This device complies with part 15 of the FCC rules. Operation is subject to the following two conditions: (1) this device may not cause harmful interference, and (2) this device must accept any interference received, including interference that may cause undesired operation.

Changes or modifications not expressly approved by the party responsible for compliance could void the user's authority to operate the equipment.

NOTE: This equipment has been tested and found to comply with the limits for a Class B digital device, pursuant to part 15 of the FCC Rules. These limits are designed to provide reasonable protection against harmful interference in a residential installation.

This equipment generates uses and can radiate radio frequency energy and, if not installed and used in accordance with the instructions, may cause harmful interference to radio communications. However, there is no guarantee that interference will not occur in a particular installation. If this equipment does cause harmful interference to radio or television reception, which can be determined by turning the equipment off and on, the user is encouraged to try to correct the interference by one or more of the following measures:

- Reorient or relocate the receiving antenna.
- Increase the separation between the equipment and receiver.
- Connect the equipment into an outlet on a circuit different from that to which the receiver is connected.
- Consult the dealer or an experienced radio/TV technician for help important announcement.

NOTE: The manufacturer is not responsible for any radio or TV interference caused by unauthorized modifications to this equipment. Such modifications could void the user's authority to operate the equipment.

## **RF Exposure**

This equipment complies with FCC radiation exposure limits set forth for an uncontrolled environment.

This transmitter must not be co-located or operating in conjunction with any other antenna or transmitter.

## **Limited Warranty**

For limited warranty, please visit <https://thirdreality.com/faq-help-center/>.

For customer support, please contact us at [info@3reality.com](mailto:info@3reality.com) or visit [www.thirdreality.com](http://www.thirdreality.com)

For question on other platforms, visit for corresponding platform's application/support platforms.